

Цветы сакуры Тосикадзу Кавасаки

Обязательная физурка

Модуль из 1-ого лепестка

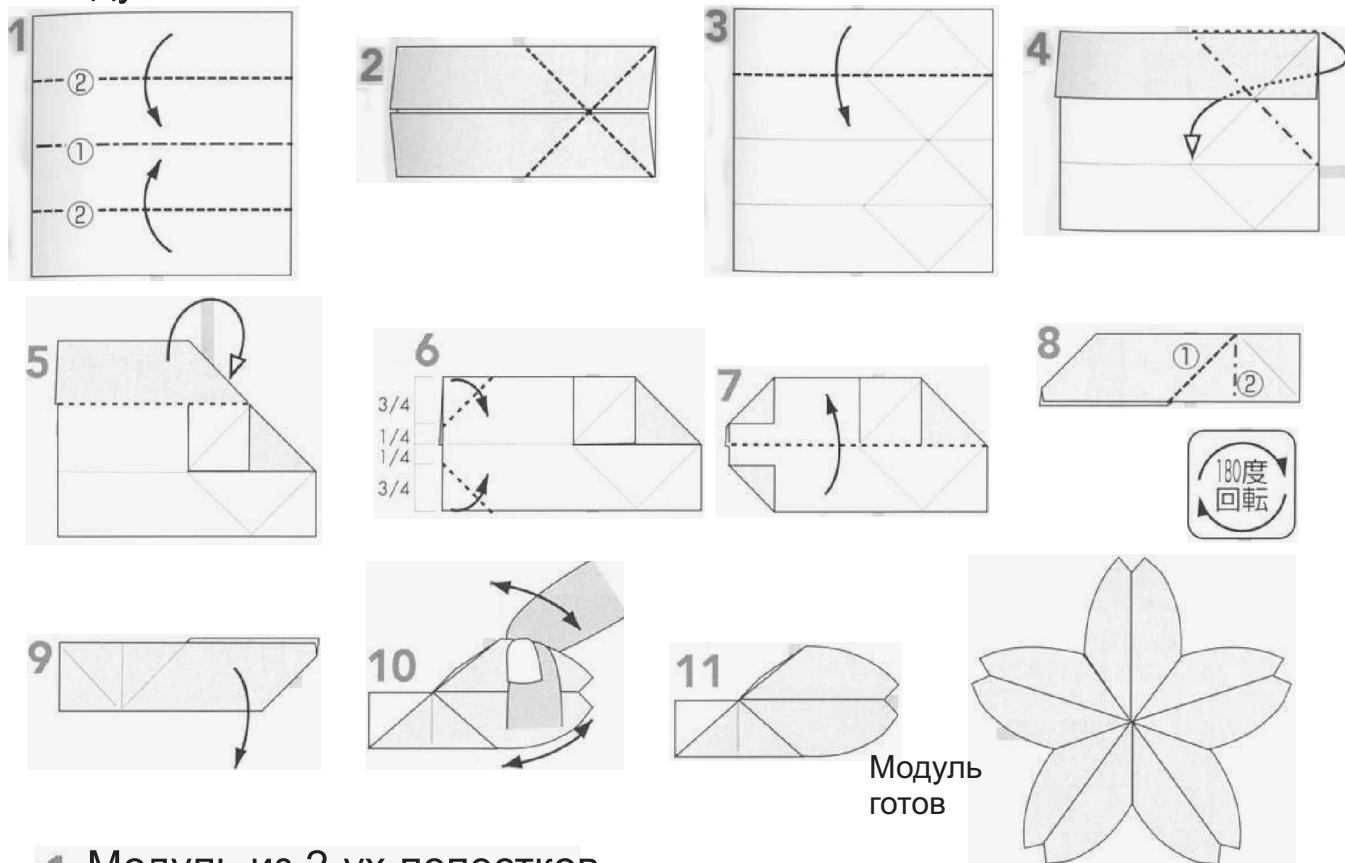

1 Модуль из 2-ух лепестков

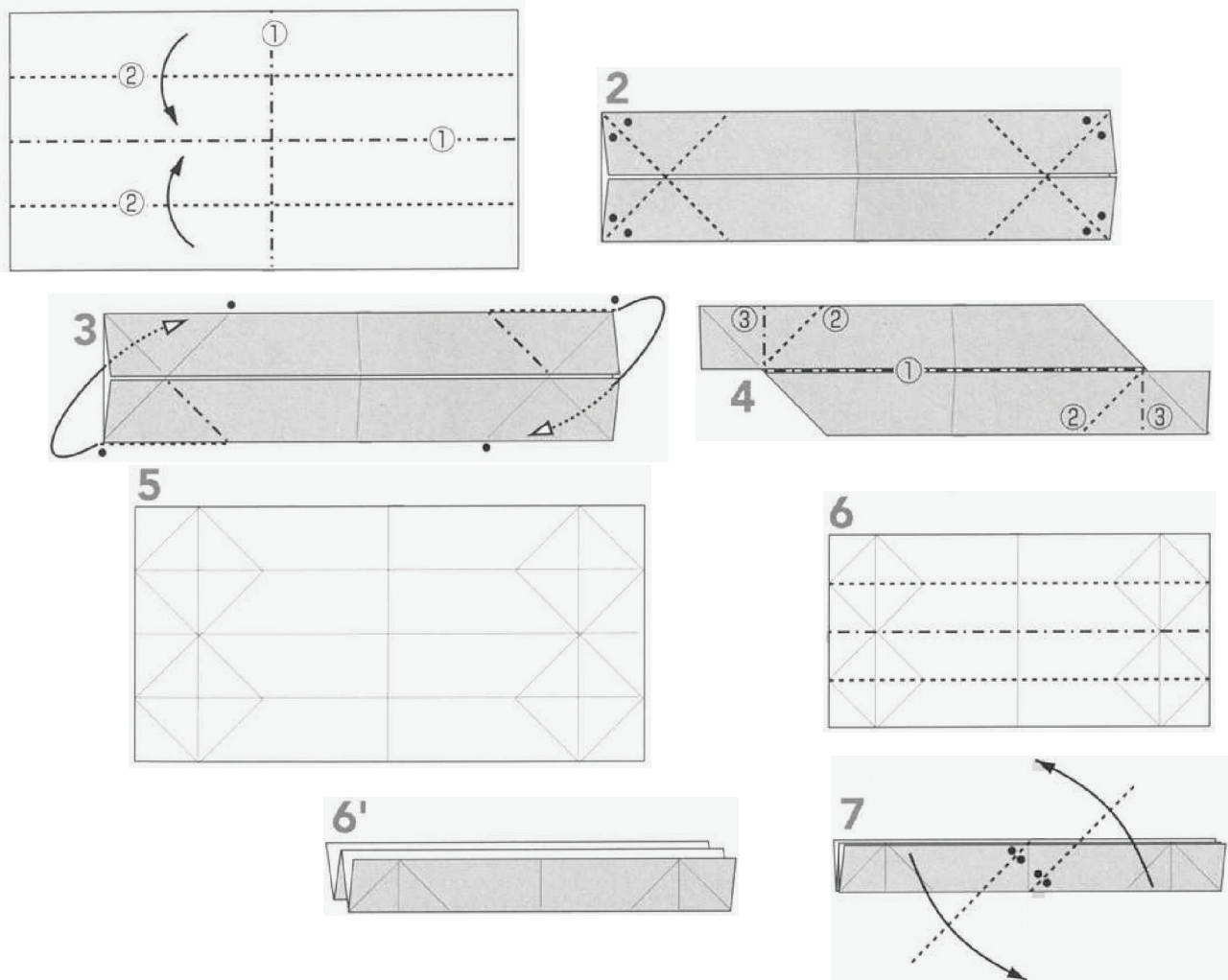

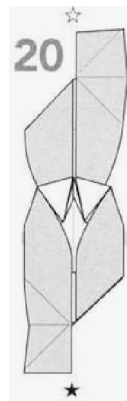
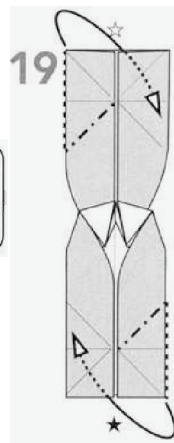
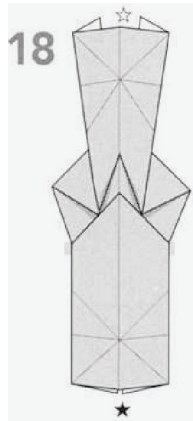
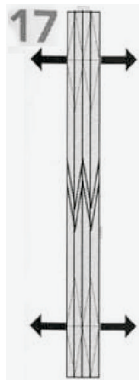
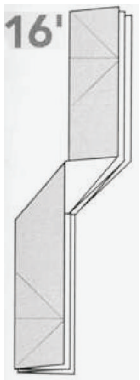
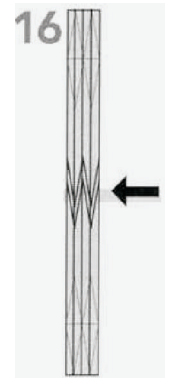
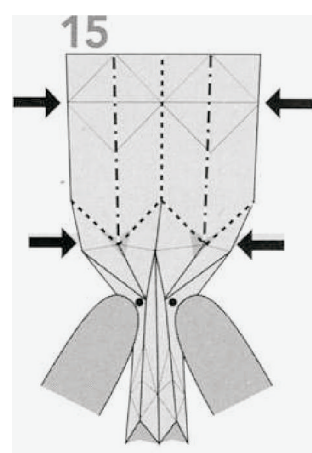
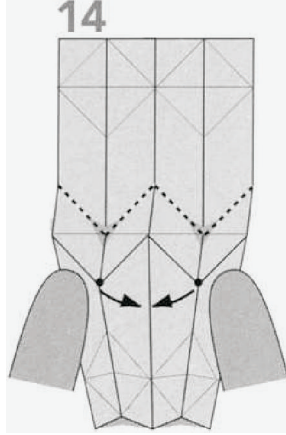
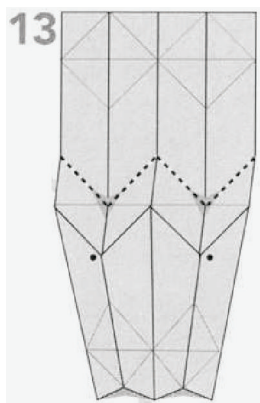
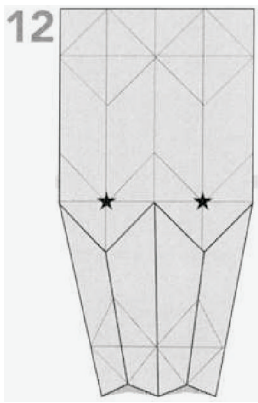
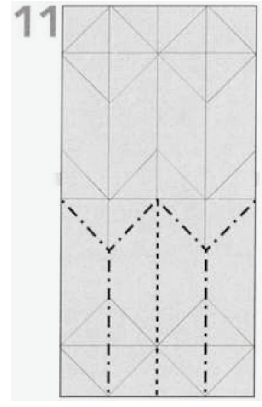
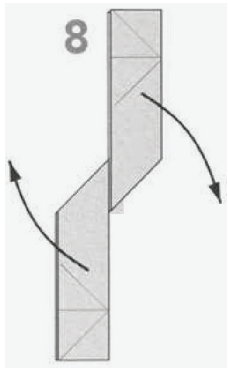

★ Модуль готов

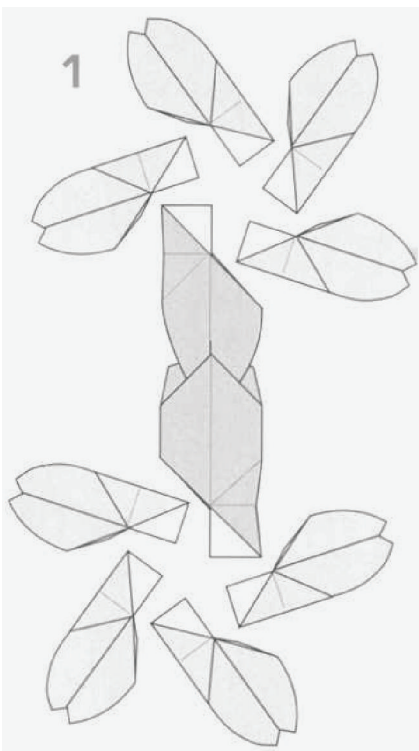

Соединяем детали

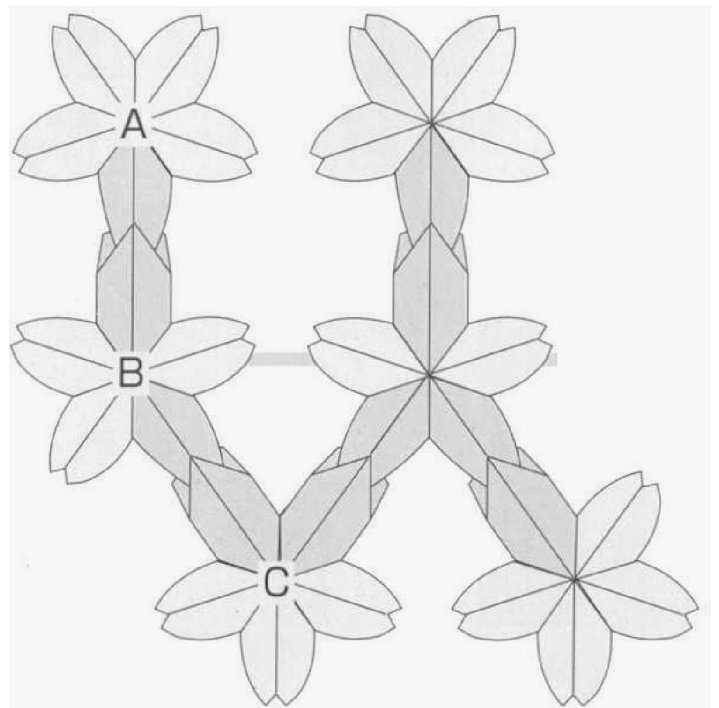
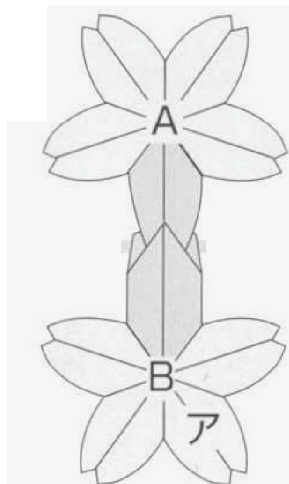

Обязательная физурка

Роза проствя Тосикадзу Кавасаки

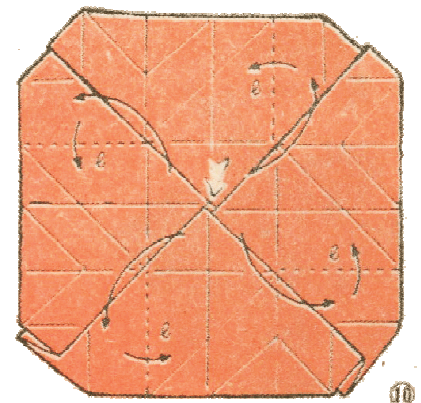
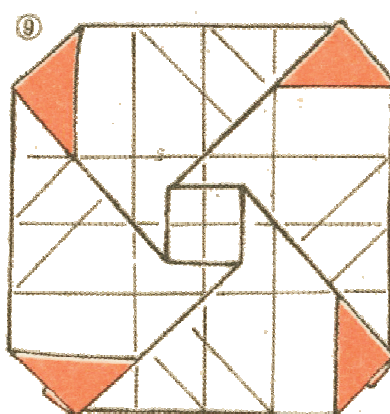
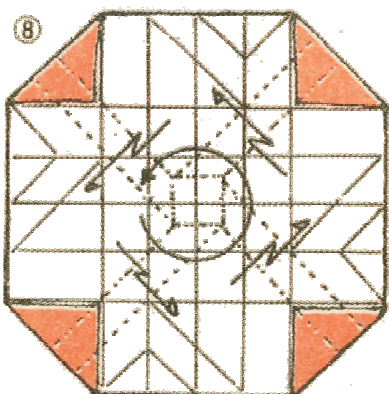
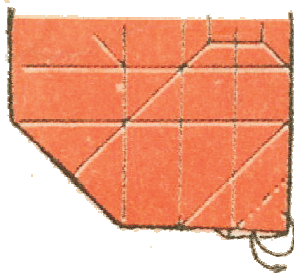
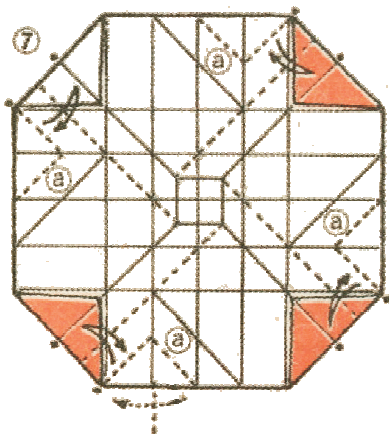
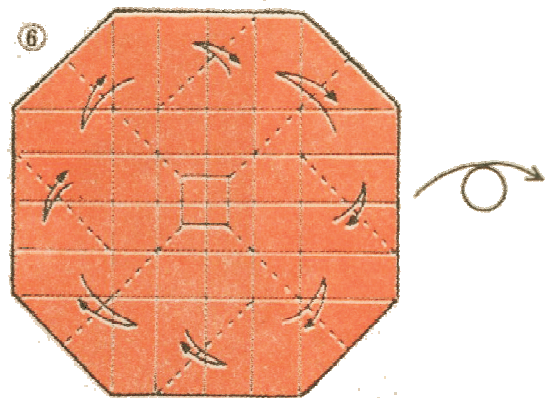
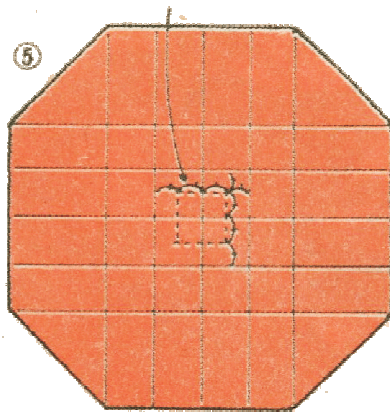
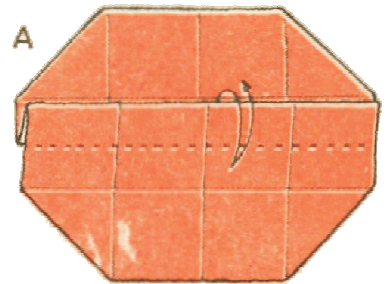
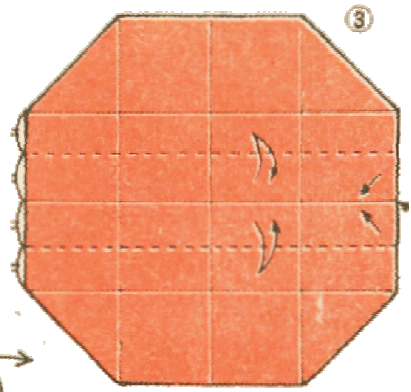
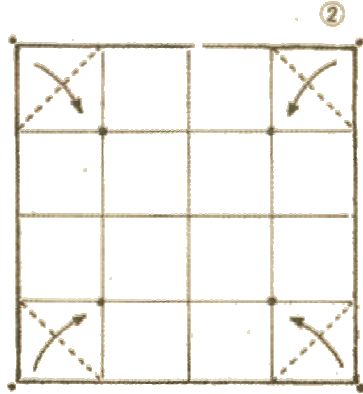
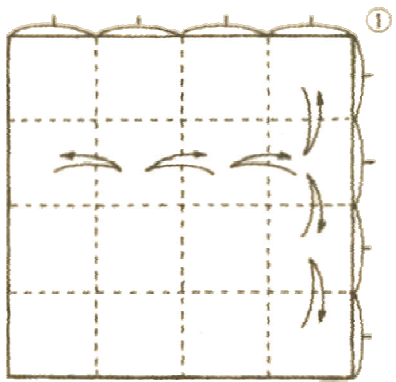

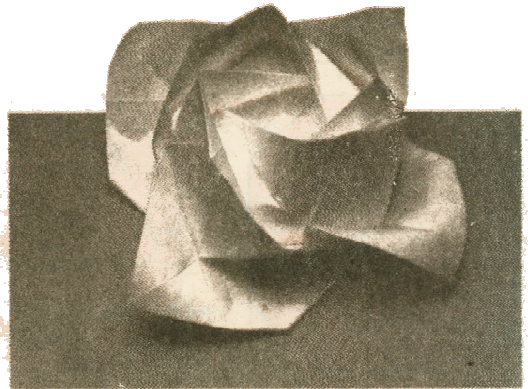
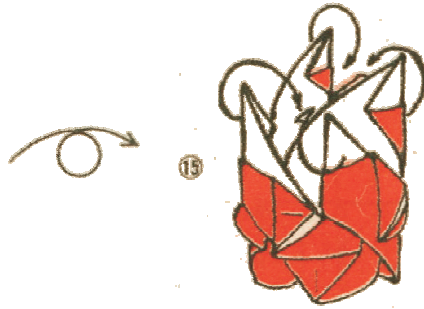
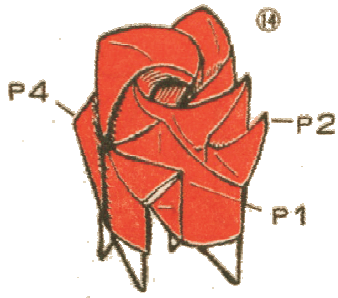
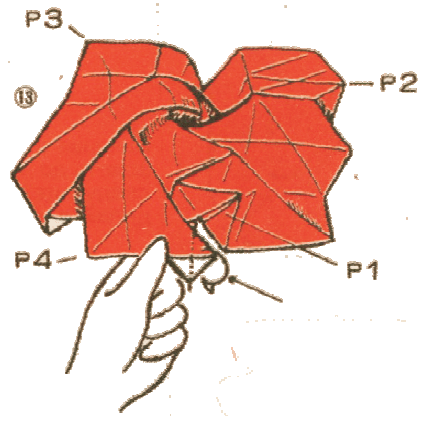
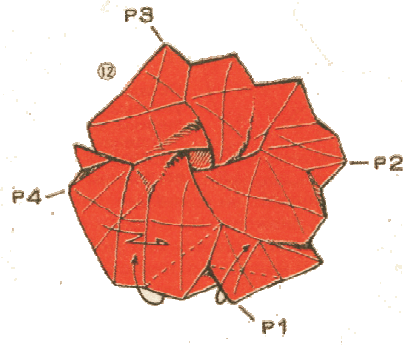
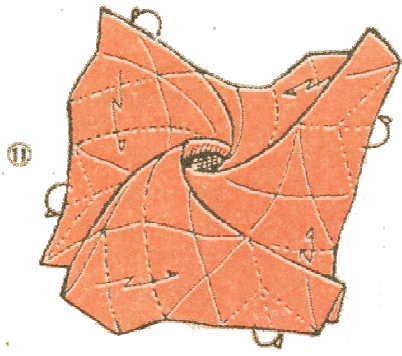

Лист для розы Тосикадзу Кавасаки

Обязательная физурка

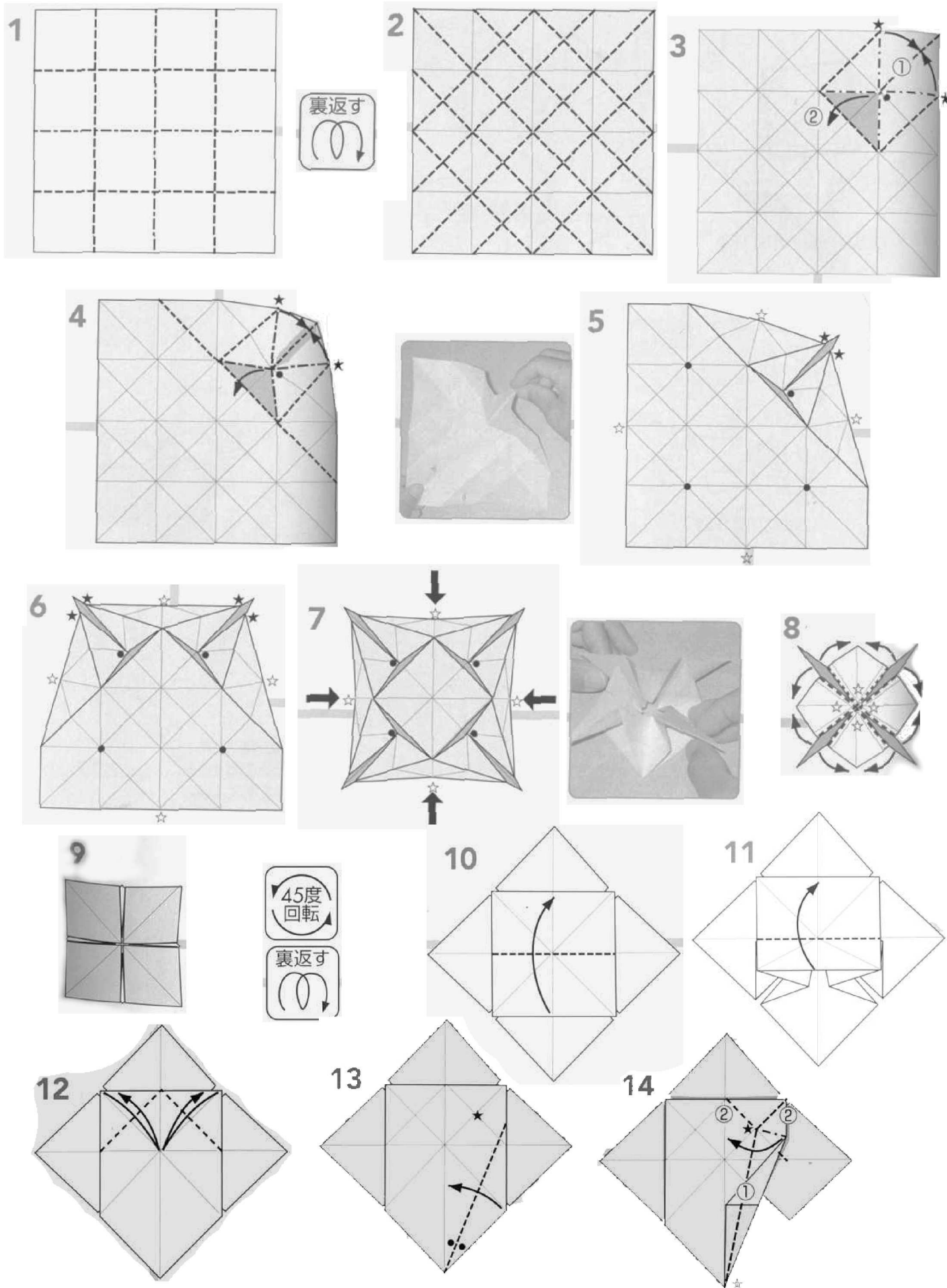

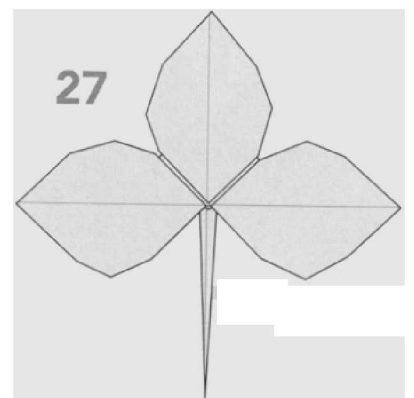
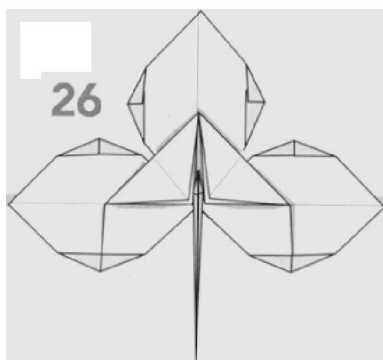
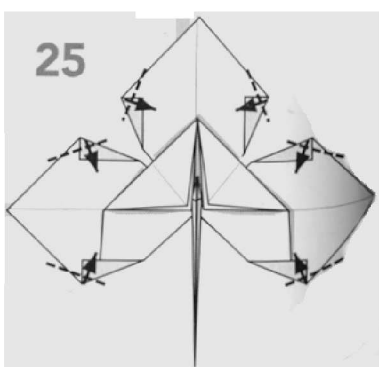
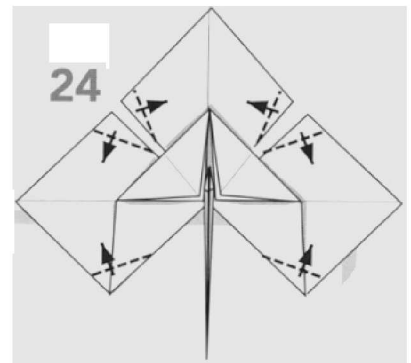
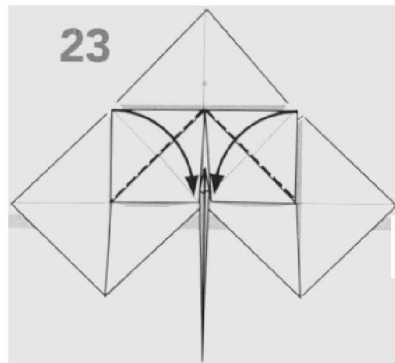
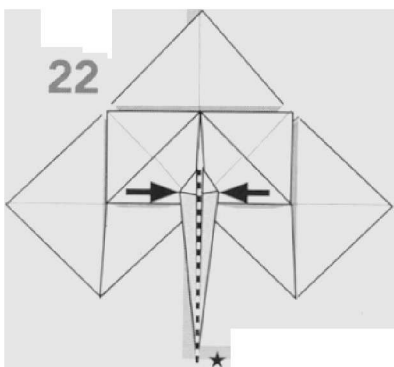
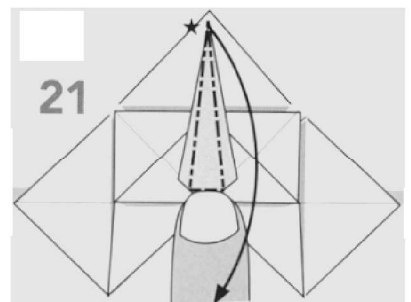
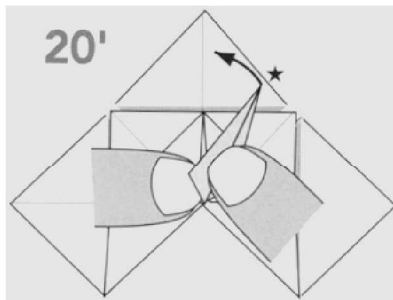
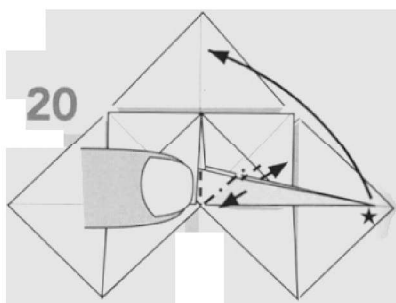
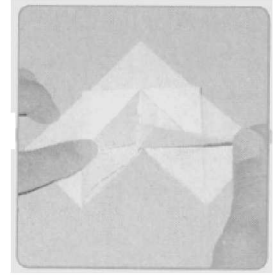
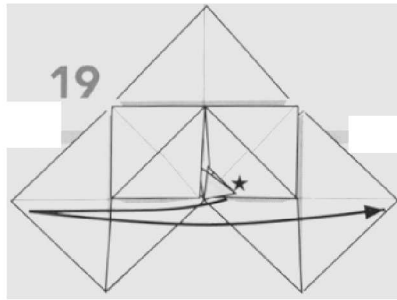
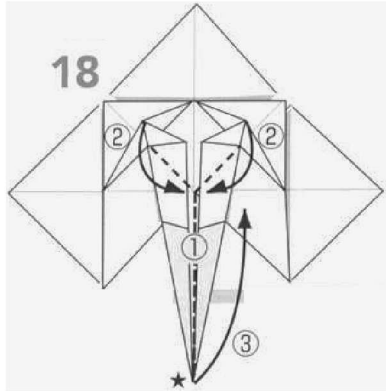
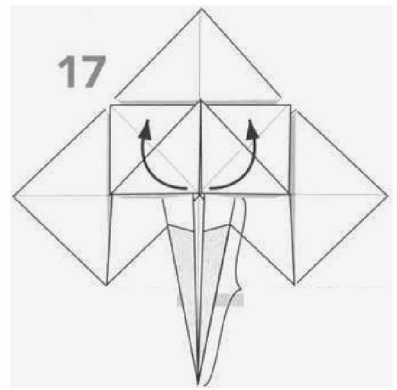
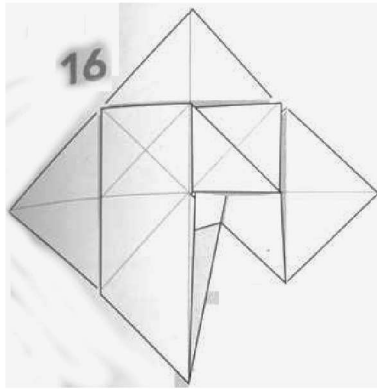
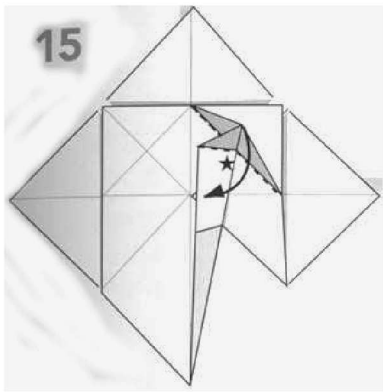

Физурка по выбору

Роза сложная

Тосикадзу Кавасаки

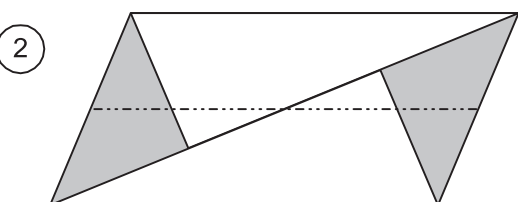
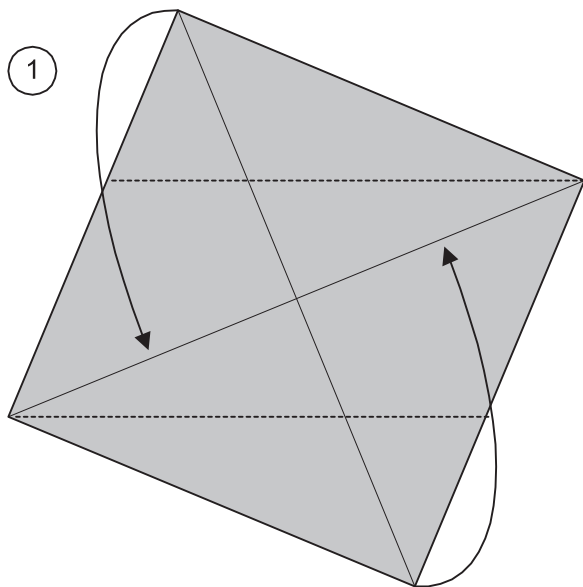

Mountain fold only the bottom layer

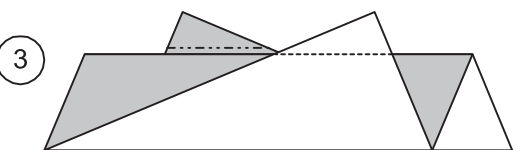

Valley fold the tip of the front layer so that it is flush with the layer behind. Repeat behind.

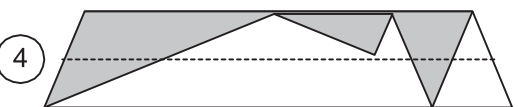

Valley fold/unfold first two layers of paper. Repeat behind

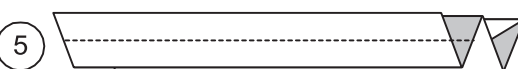

Valley fold/unfold first four layers of paper. I recommend that the folder fold at most two layers of paper at a time to avoid paper drift. The type of fold (valley or mountain) is unimportant at this point in folding

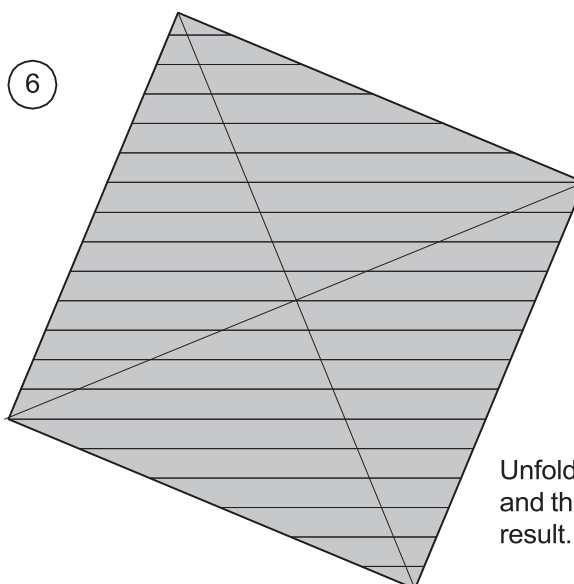

Unfold steps 1 to 4 and this is the result.

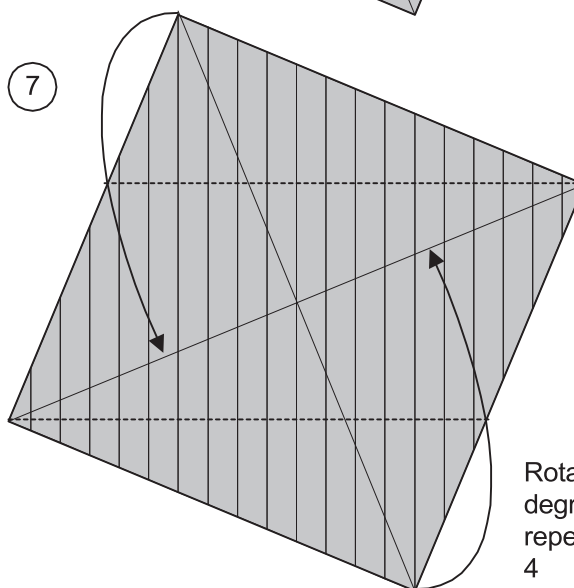

Rotate 90 degrees and repeat steps 1 to 4

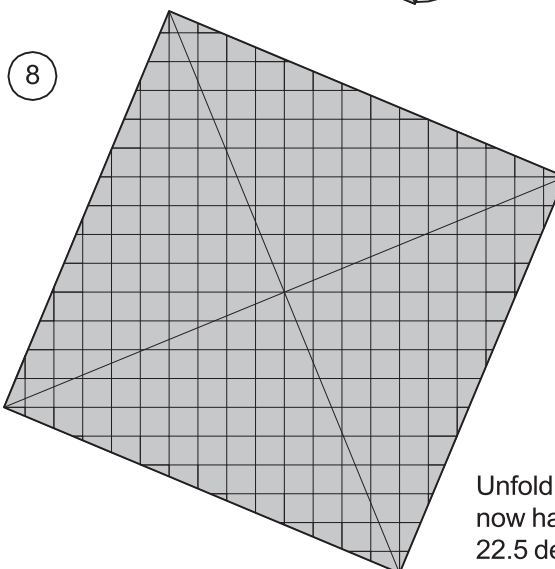

Unfold and you should now have a grid on a 22.5 degree angle.

Kawasaki Rose	1/5
Designer: Toshikazu Kawasaki	
Diagrammed By: Winson Chan	
Revision: 2.1	Date: 4/29/96

9

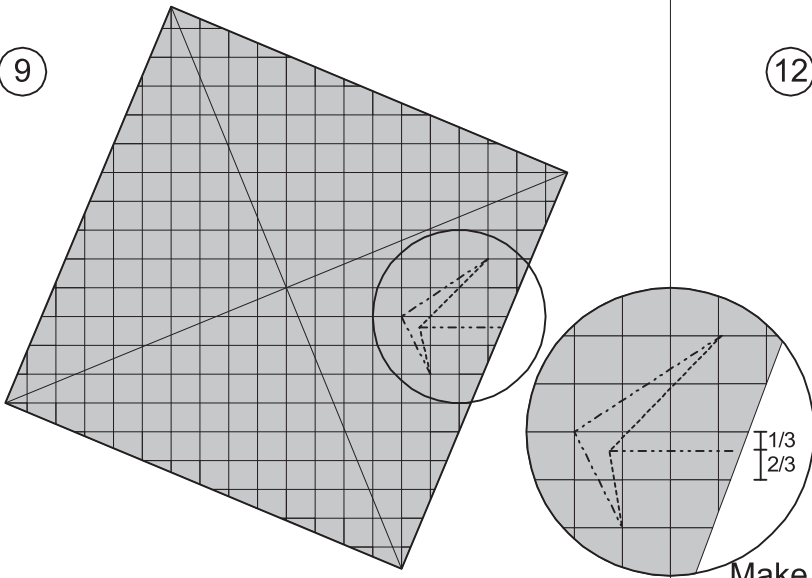

Make the following mountain and valley folds. See enlargement. Notice the position of the horizontal crease. Repeat on all four sides

10

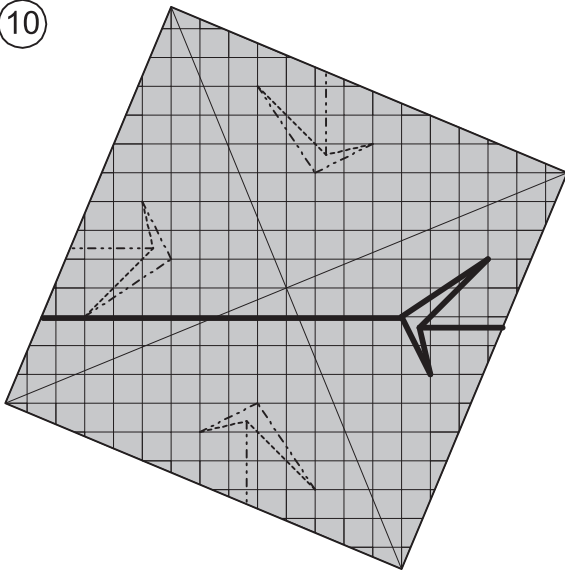

The paper should look like this after completing each set. Reinforce each set of folds by crimping along the darkened line.

11

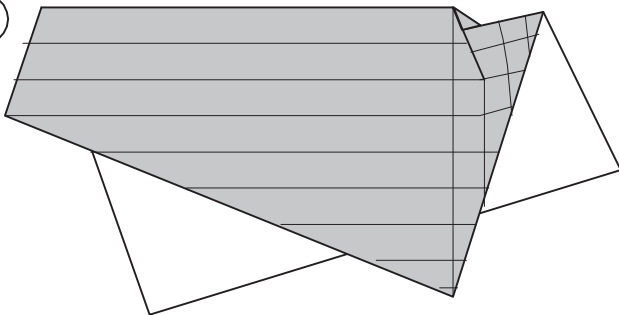

This is what one of the crimps looks like. Repeat on all four sets.

12

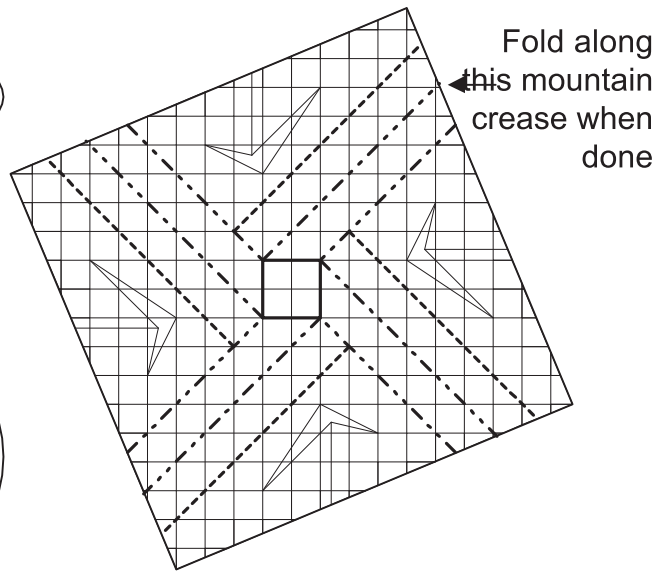

Make the following mountain and valley folds. They are at 45 degrees relative to the grid. The square in the centre can be used as a guide. When these creases are complete, mountain fold along the crease indicated, the entire length of the paper

13

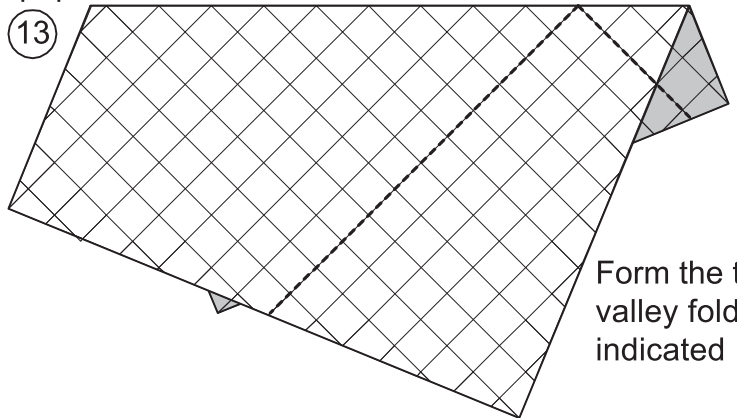

Form the two valley folds indicated

14

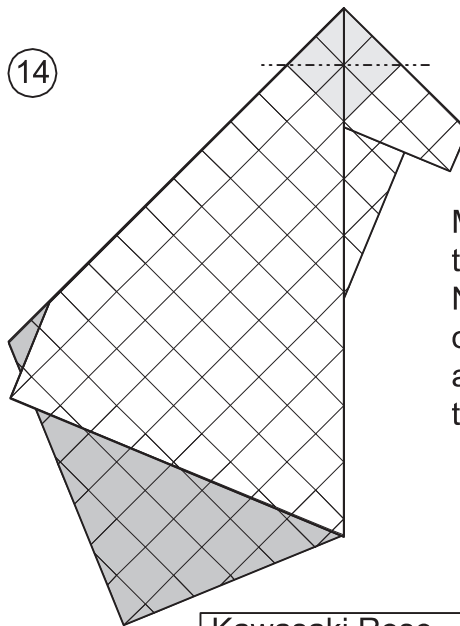

Mountain fold the top point behind. Notice the location of the light gray area over the next three steps.

15

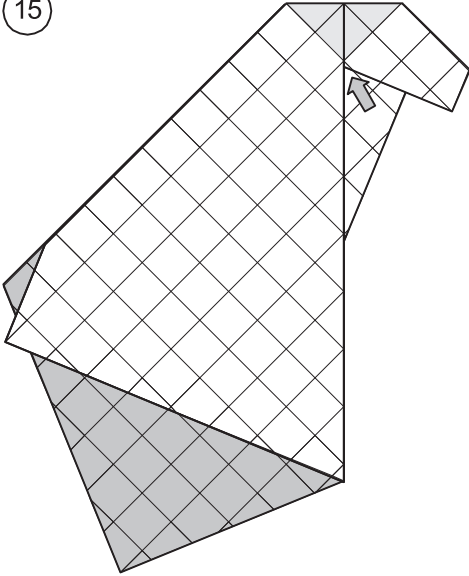

Open up the model by inserting a finger into the section indicated. Model will not remain flat. Notice the movement of the light gray section

16

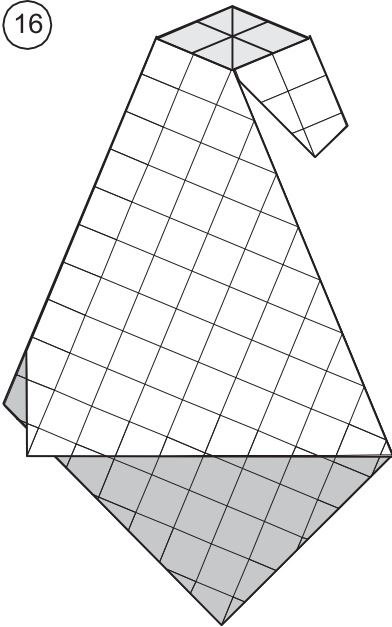

Unfold model to step 12.

17

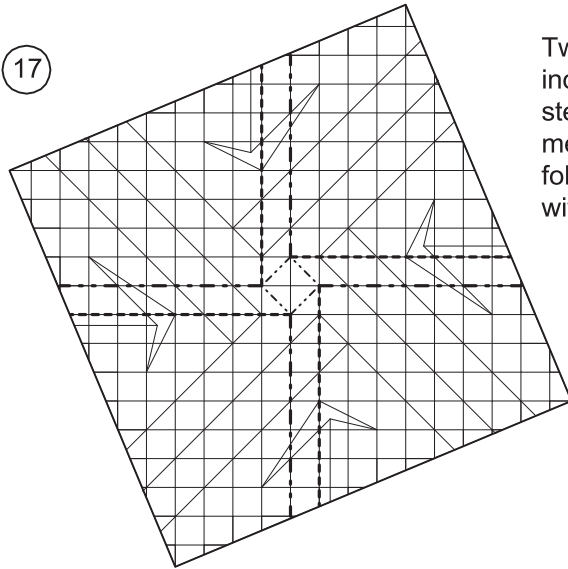

Twist fold along the lines indicated. The next 2 steps provide a simple method of doing a twist fold if you are not familiar with it.

18

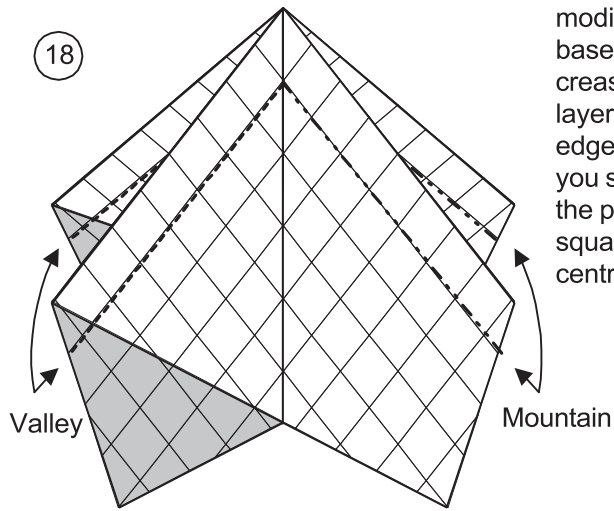

Form a (slightly modified) waterbomb base along existing creases. Fold both layers of paper on each edge as indicated, while you spread out/flatten the paper. Carefully squash the paper in the centre into a square.

19

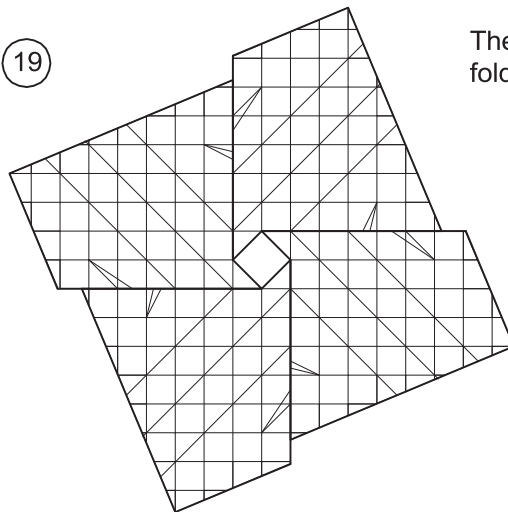

The model after the twist fold. Flip paper over.



Kawasaki Rose	3/5
Designer: Toshikazu Kawasaki	
Diagrammed By: Winson Chan	
Revision: 2.1	Date: 4/29/96

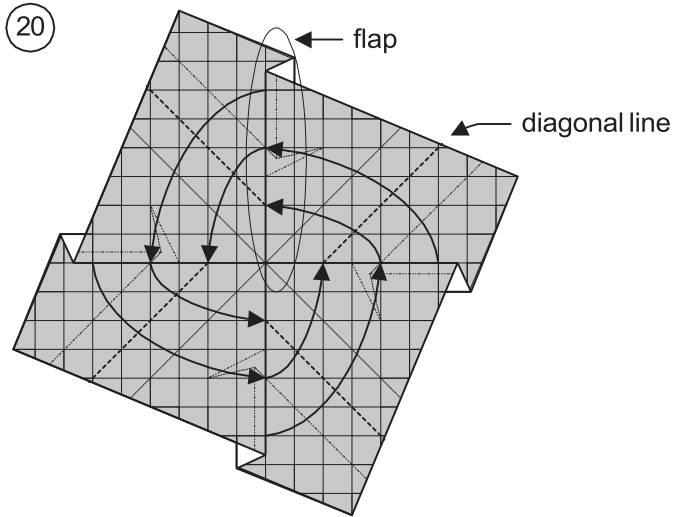

Bring together the flaps formed by the twist fold. Valley fold along the diagonal line to help with this. Model will not remain flat, and should resemble a cylinder. Make sure that the centre points up, not down.

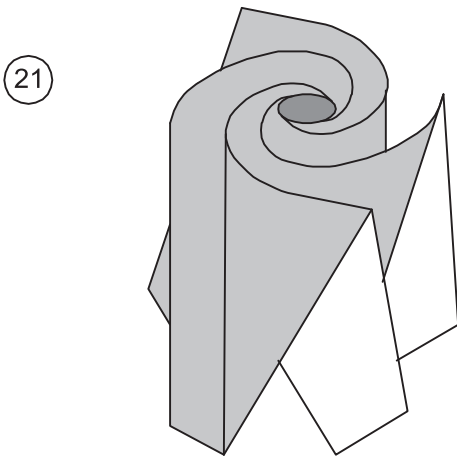

To create the cylinder like appearance of the model, place one hand around the model, insert one finger (of the other hand) and rotate finger clockwise. Be careful not to make break the paper. The model will wrap tightly around your finger. This step will improve the look of the model and is not essential.

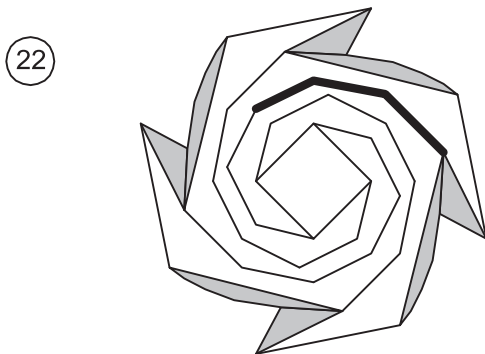

View from the bottom of the rose before the reverse folds. Notice the movement of the darkened line. See step 25.

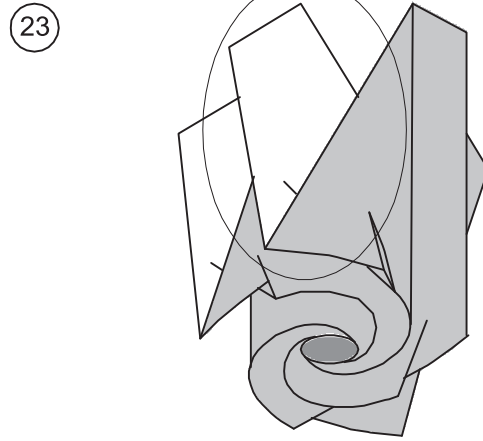

Re-form the crimps in step 11. Turn the model upside down. Notice the enlargement of the indicated area in the next step. The next few steps will consist of re-forming the folds in steps 13 to 16. This will lock the base of the rose.

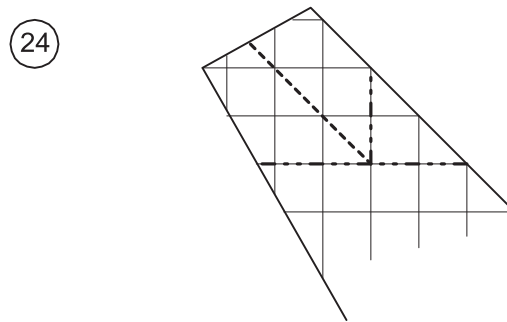

Enlargement of the indicated area in the previous step. No new creases are needed. All creases were folded in correct direction (mountain or valley) in steps 13 to 16. Make sure to fold both layers of paper. The folder should realize this fold is essentially a reverse fold. A review of a reverse fold is found on page 5.

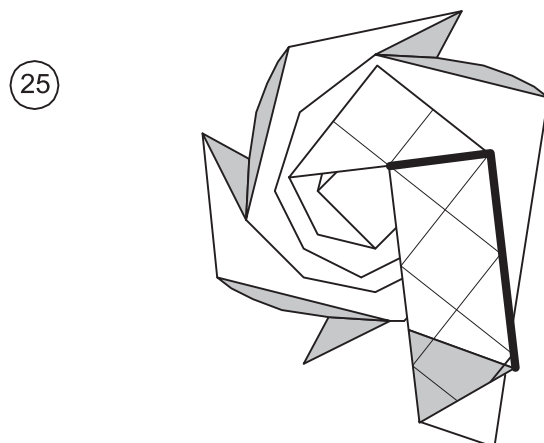

This is what the model looks like. Notice the darkened line, and compare it with the diagram in step 22. Repeat this with all 4 flaps.

Kawasaki Rose	4/5
Designer: Toshikazu Kawasaki	
Diagrammed By: Winson Chan	
Revision: 2.1	Date: 4/29/96

26

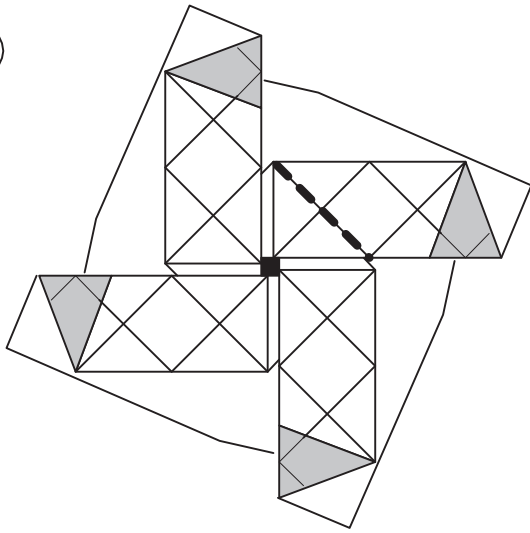

This is what the model looks like after the inside reverse fold on each flap. It is essential that the hole in the centre is as small as possible. Try pulling on the flaps to reduce the size of the hole. Next, do an outside reverse fold (on the two layers) so that it wraps back around the model.

27

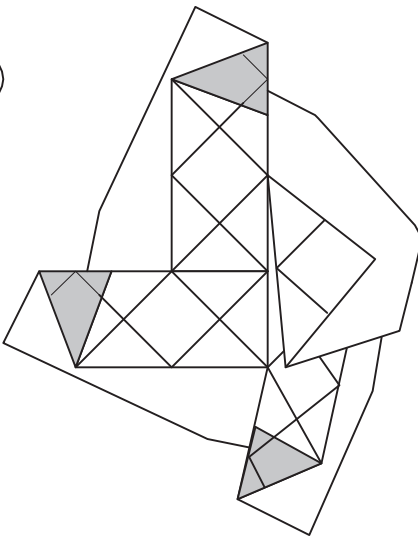

This is what the model looks like after one outside reverse fold. Notice how we have now refolded steps 13 to 16. Now do the same on the remaining 3 flaps so that the four flaps overlap each other. The last fold is the most difficult.

Inside Reverse Fold

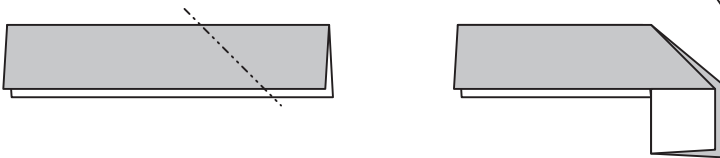

Outside Reverse Fold

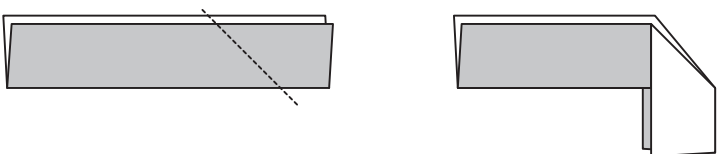

28

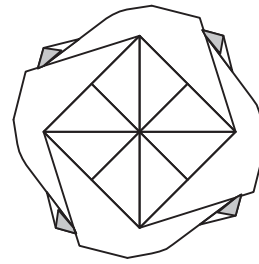

The underside of the completed rose. The rose is now essentially done. Flip the rose over, reform the centre by inserting a finger and rotating it clockwise as in step XX. Form petals into desired shape. The rose is now complete.

29

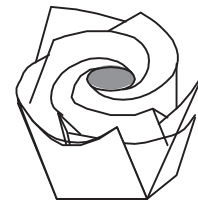

A very poor drawing of the top of the rose. I'll fix it in my next revision!

Have Fun!

The Kawasaki Rose was taught to me (the diagrammer) by Joseph Wu, who was taught by Toshikazu Kawasaki at the Convention in New York in 1994.

You can make copies of these diagrams for personal use and for friends, but do not make large number of copies for wide distribution (i.e. at a Convention). 1996

Kawasaki Rose	5/5
Designer: Toshikazu Kawasaki	
Diagrammed By: Winson Chan	
Revision: 2.1	Date: 4/29/96

Фигурка по выбору

"Лист розы" Владимира Серова

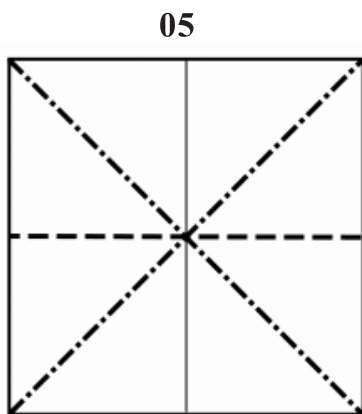
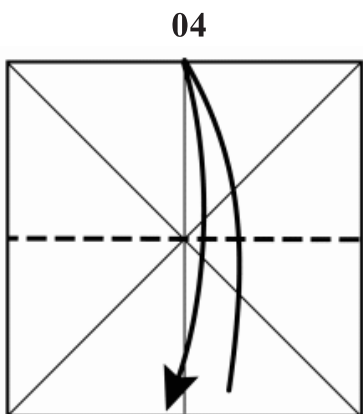
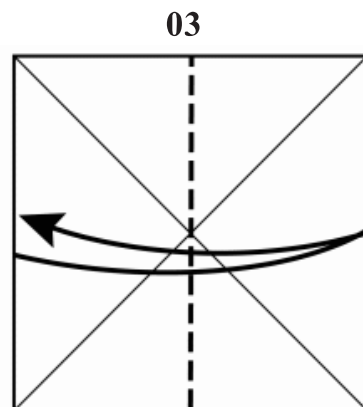
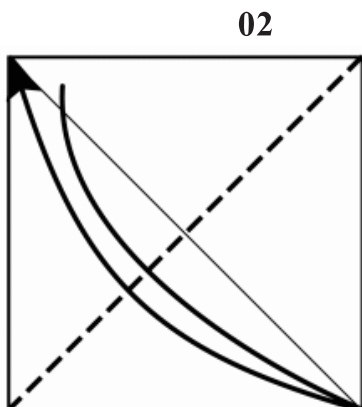
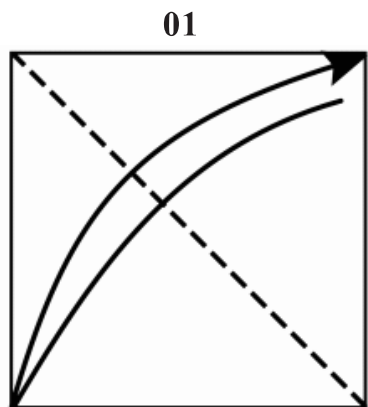

свернуть базовую форму
"двойной треугольник"

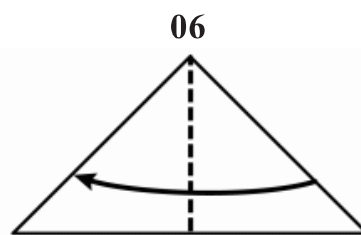

отвернуть один слой влево

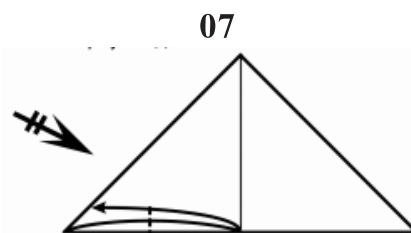

наметить середину
на всех трех слоях

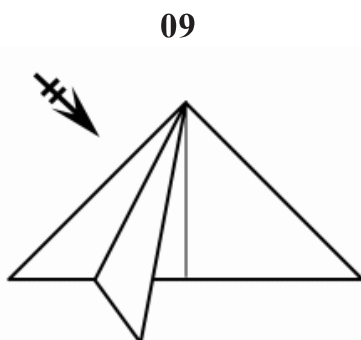
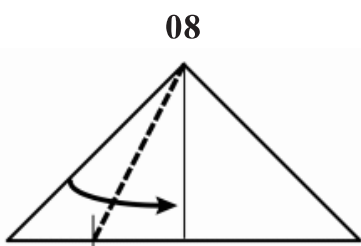

повторить п.8 на двух слоях

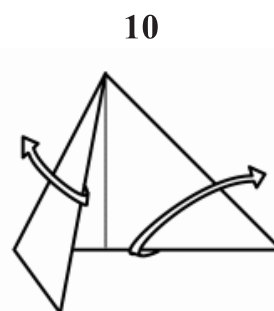

развернуть до квадрата

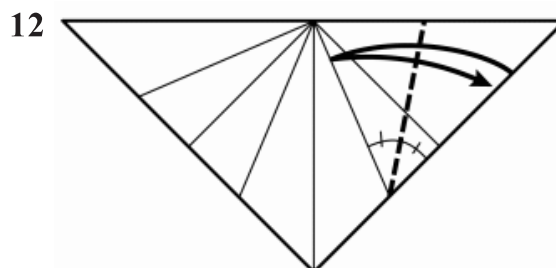
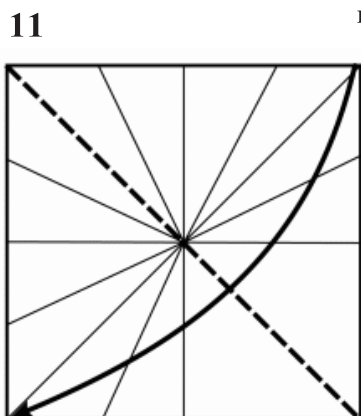

13

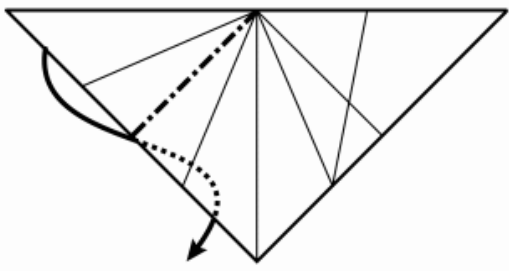

14

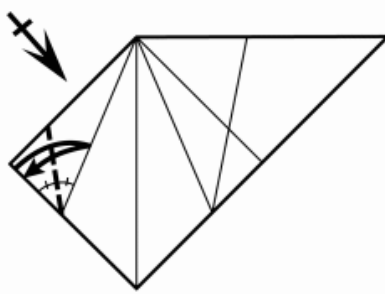

15

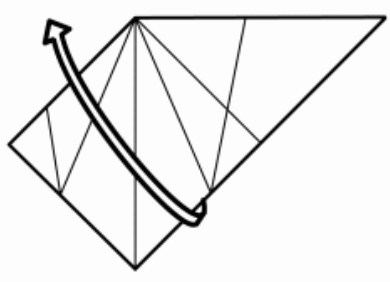

развернуть до квадрата

16

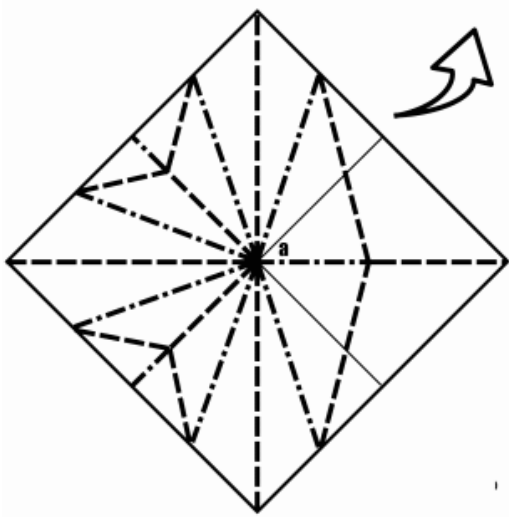

сложить сразу по всем указанным линиям, вершина (а) торчит вверх

17

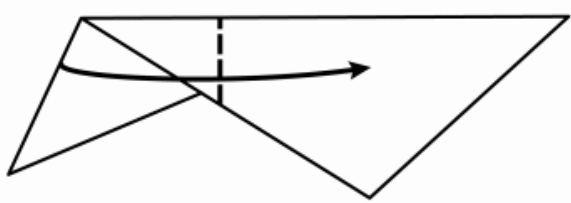

отвернуть один слой вправо

18

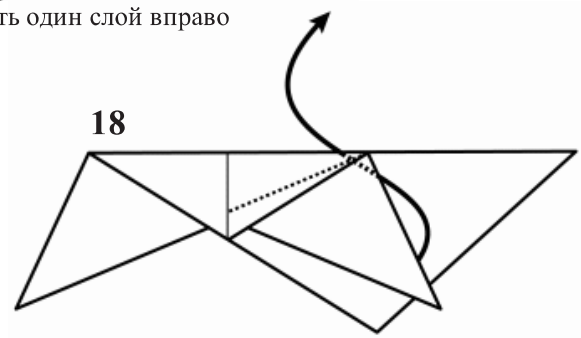

вогнуть как по волеет бумага

19

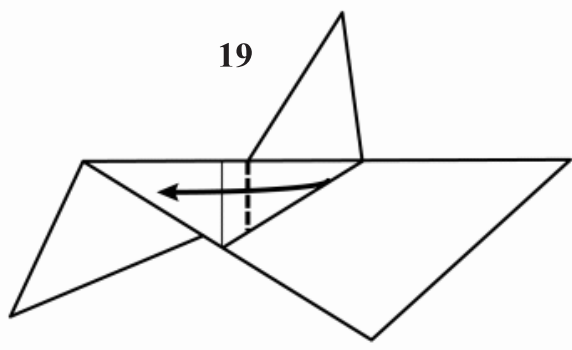

20

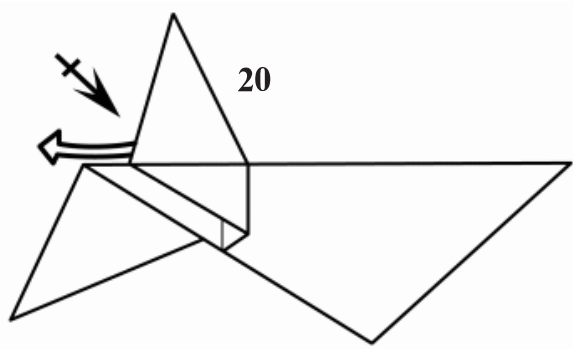

сдвинуть передний слой влево до упора и повторить п п 17-20 с дальним слоем

21

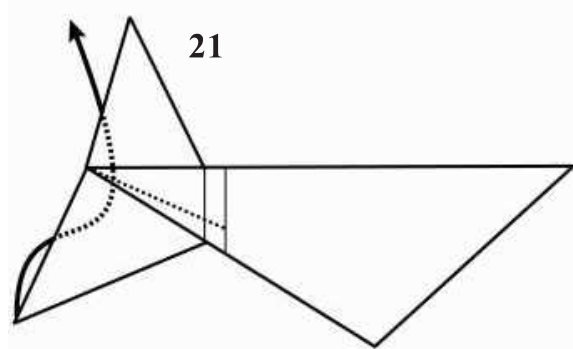

вогнуть второй слой

22

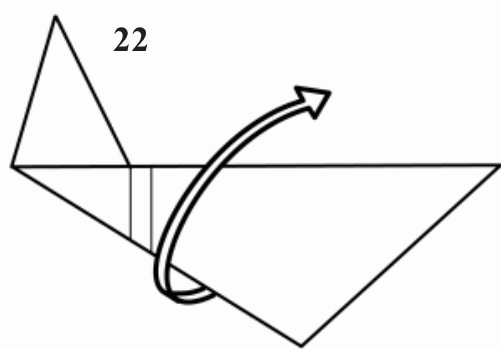

развернуть до квадрата

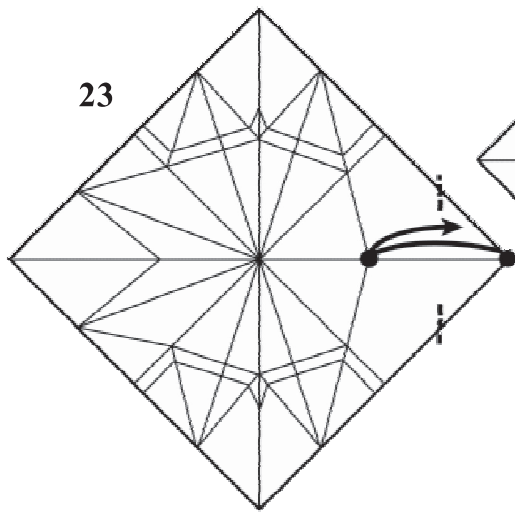

23

наметить точки

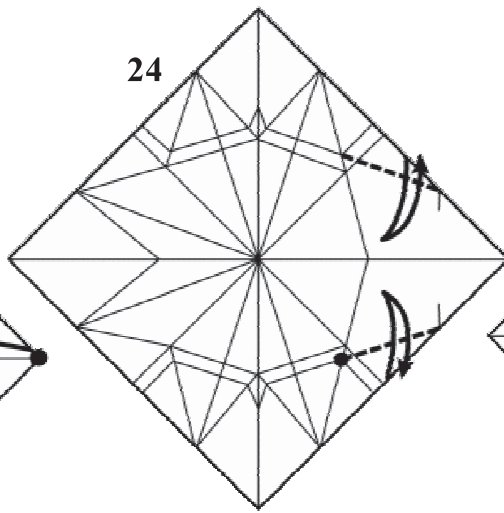

24

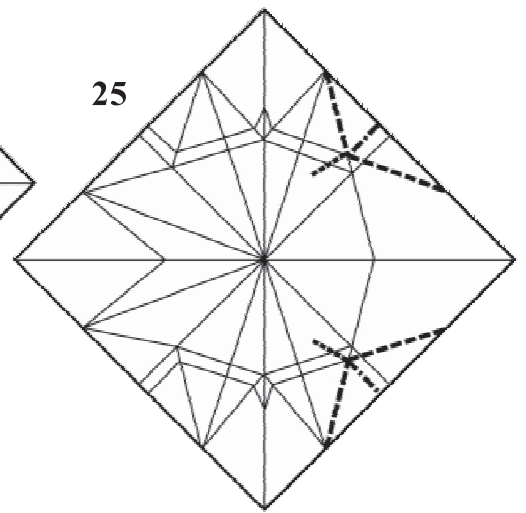

25

свернуть и развернуть по намеченным ранее линиям, чтобы получить новую "долину"

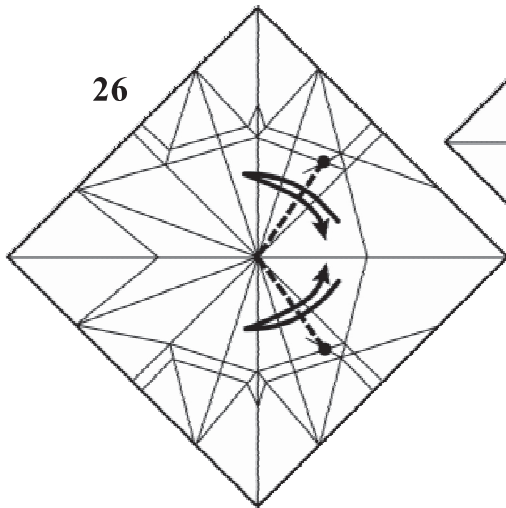

26

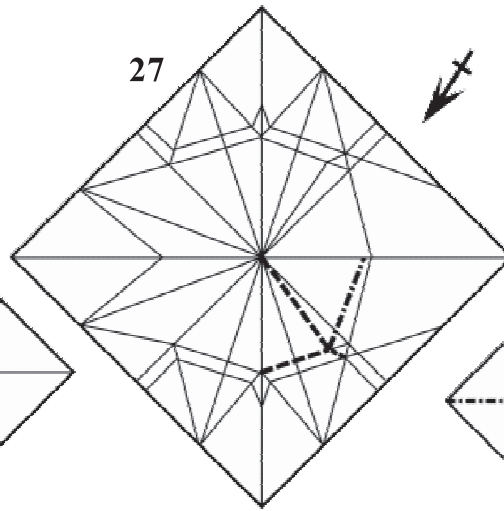

27

сложив по трем "долинам", получаем новую складку - "гору"

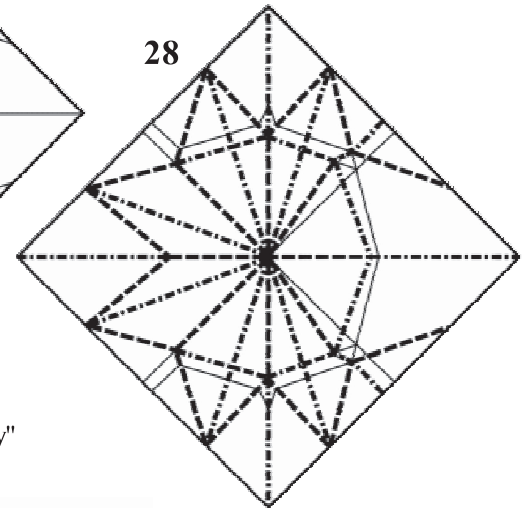

28

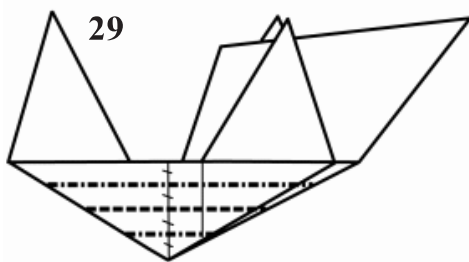

29

необходимо наметить указанные линии, но это проще делать на каждом слое в отдельности, разворачивая до необходимого состояния (см.п.п.29а-29f). А затем развернуть до квадрата

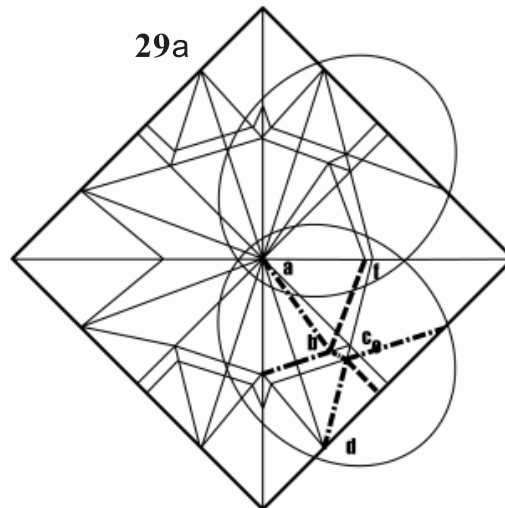

29а

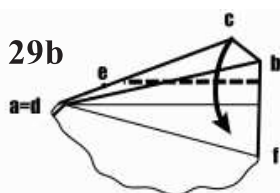

29b

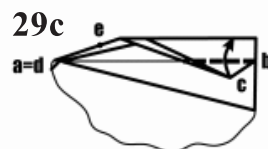

29c

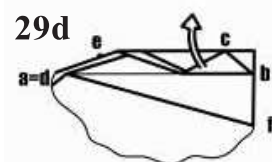

29d

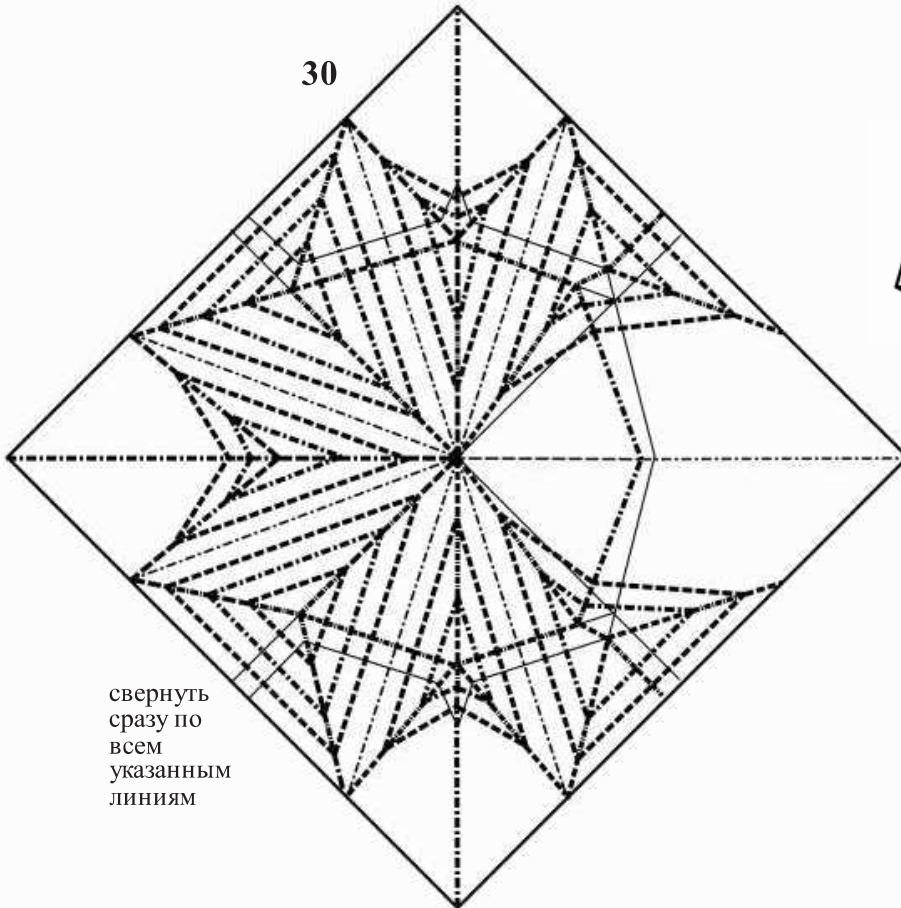
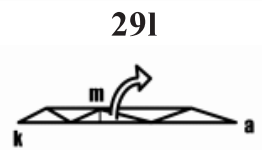
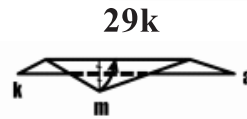
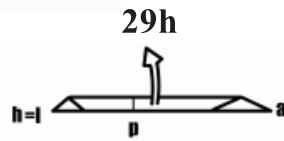
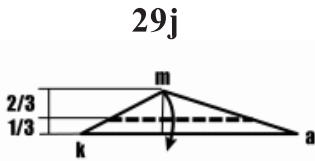
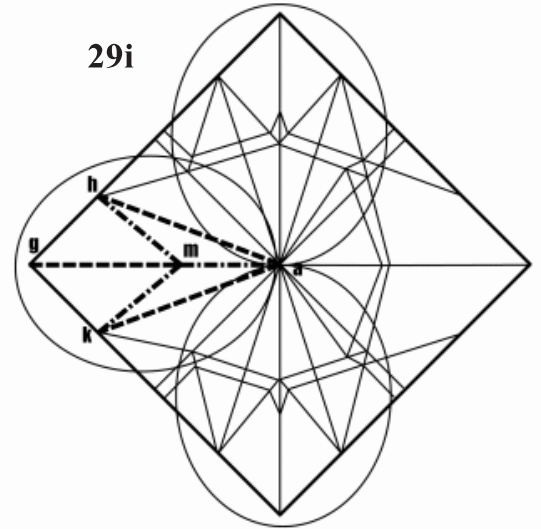
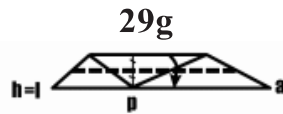
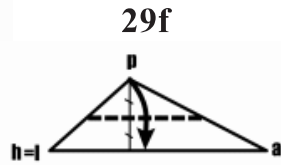
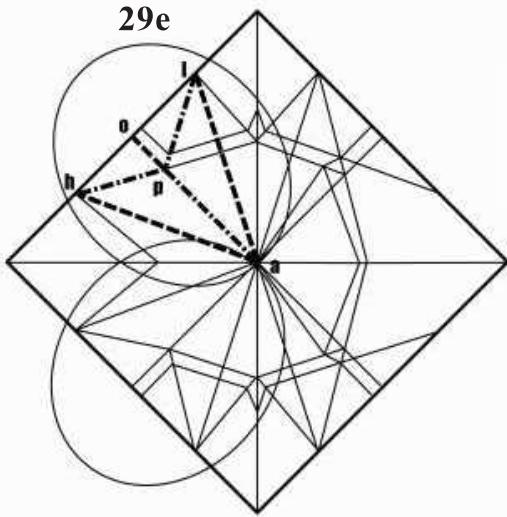

свернуть сразу по всем указанным линиям

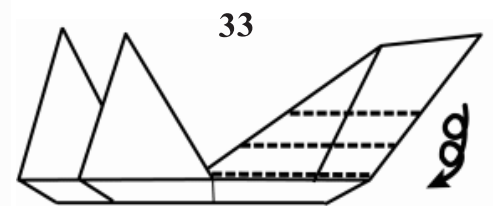
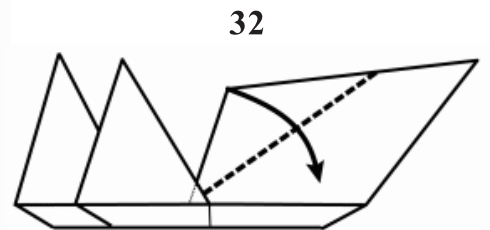
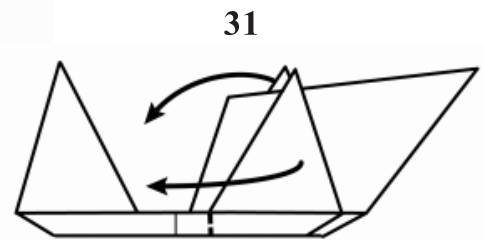

излишек бумаги закрутить вокруг черенка

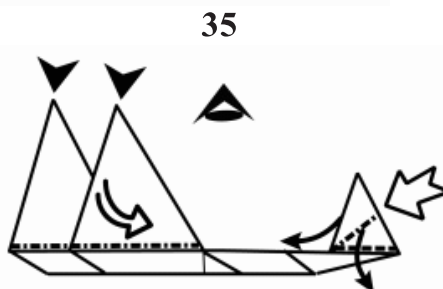
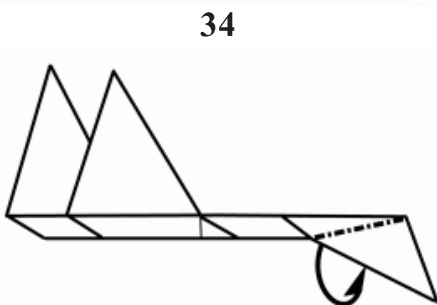

кончик черенка раскрыть и расплющить, а нижние листочки отогнуть перпендикулярно черенку. Все листочки расплющить, раздвигая концы в стороны, и дальше смотреть сверху

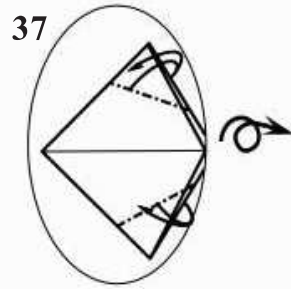
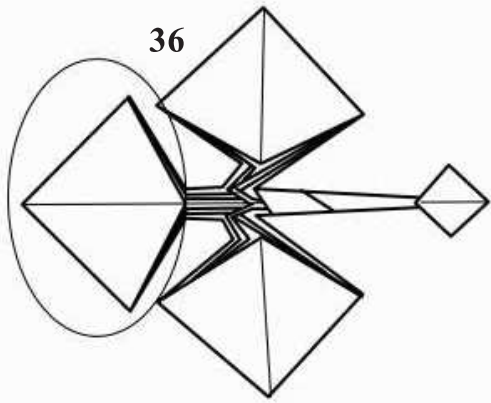

наметить линию и перевернуть фигурку

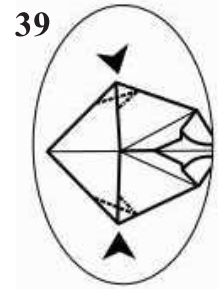
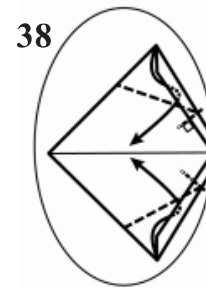

вогнуть уголки

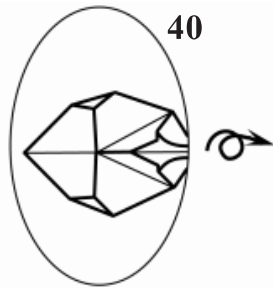

п.п.39-40 повторить с оставшимися двумя листочками и перевернуть фигурку

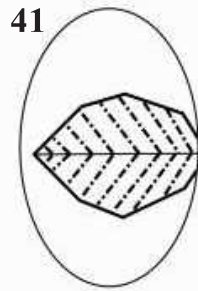

наметить жилки на всех листочках

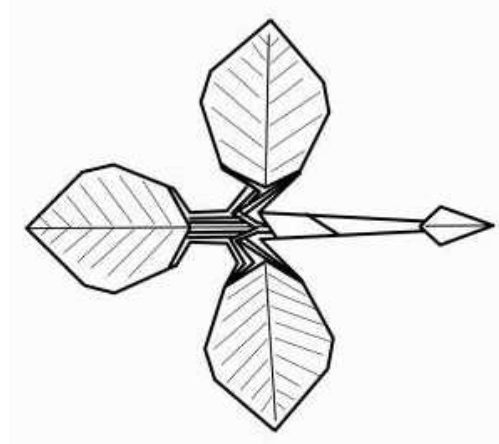

花の章 / 2022

Step▶2 つつじ大パーツを作る

練習用紙 15cm×15cm以上
本番用紙 15cm×15cm (一辺が小パーツの2倍のサイズ)

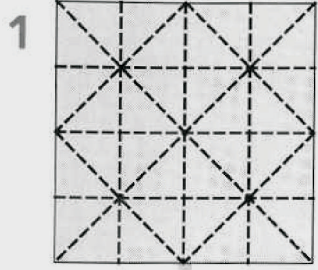

①縦横4等分の谷折り線をつける
②ななめ45°に谷折り線をつける

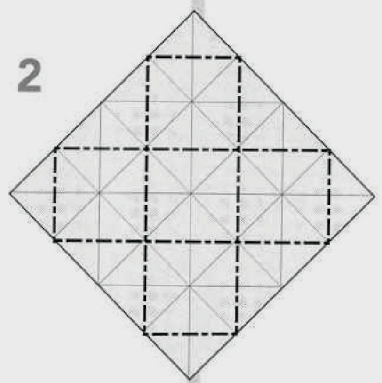

工程1の谷折り線の間
に、山折り線をつける

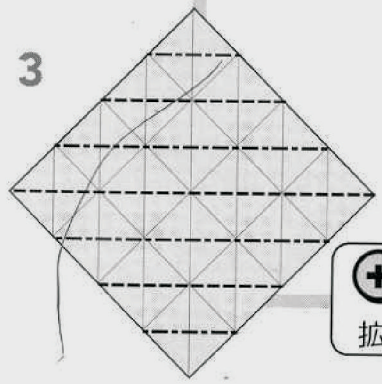

じゃばら折りする

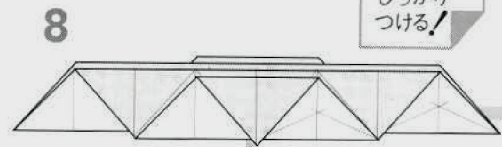

工程4~7をくり返す

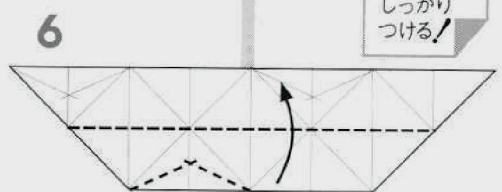
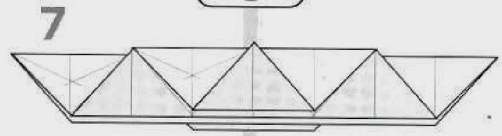

今度は左側で1カ所だけへの字谷折りして、まためくる

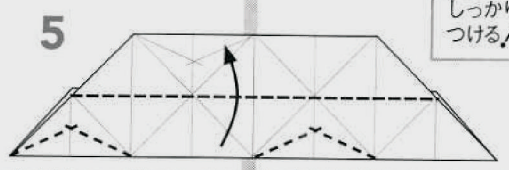

左から1つ置きにへの字谷折りを2カ所してから、1枚めくる

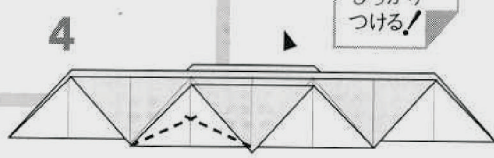

左側でStep1の工程3~5 (41ページ) と同様にへの字谷折りしてから、1枚めくる



ひろげる

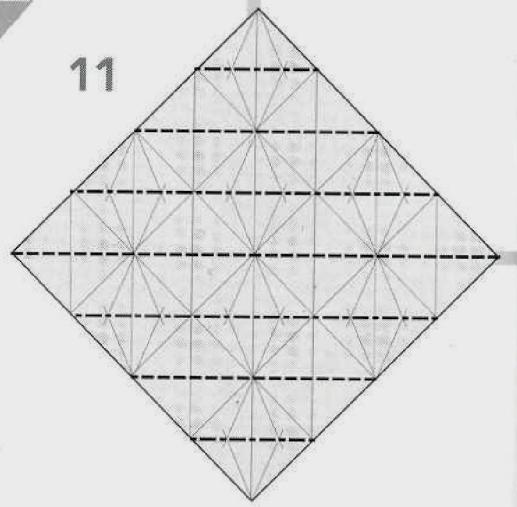
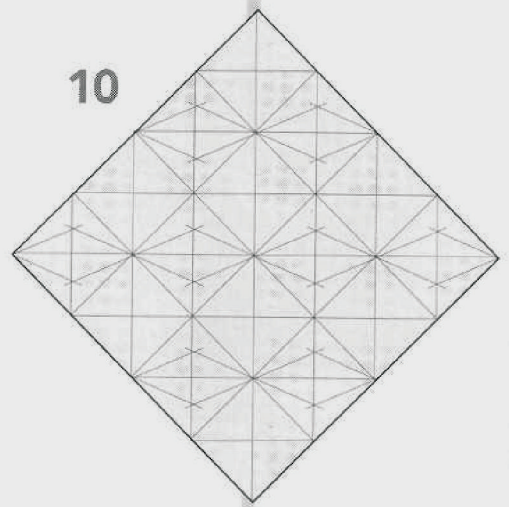

工程3同様にじゃばら折りする

谷 山 谷

「への字谷折り」は2枚重ねで折るので、山折りと谷折りが対でつきます。この先の工程では、裏から見た谷折り線の方だけを使うので、山折り線は省略します。

注意!

13'

伸びきったところでぴんと張ると極太線が背骨のような山折り線になる

13

やさしく扱う!

ゆっくり引っ張って伸ばす

12

折り目をしっかりつける!

工程4と左右逆に右端でへの字谷折りし、以下工程9まで同様にする(工程5は、右端と右から3番目を折る)

カクン折り

14a

1点鎖線(背骨)を軽く山折りする

14b

①背骨をぼきんと折るようにして、破線をへこませる
②への字谷折り線をへこませる

14c

★を☆に合わせる

14d

カクン折り完了

14

濃い正方形を上のようにカクン折りする

HINT

極太線を背骨とよぶ。1点鎖線は山折り線、破線は谷折り線になっている。

1つ目のカクン折り

次ページへ

15

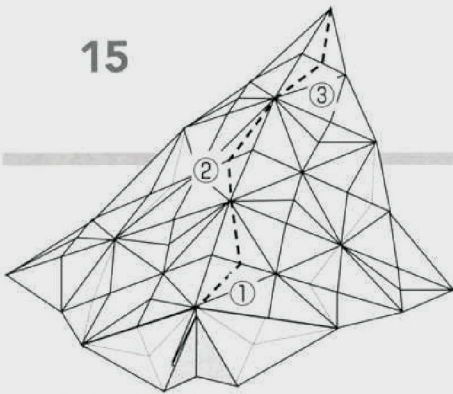

①②③の順にカクン折りする

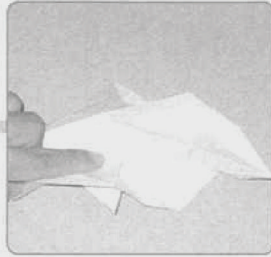

工程15の①と③のカクン折りは、工程14と左右が逆になる

すべてカクン折りすると自然にじゃぼら折りされて、工程16になる

16

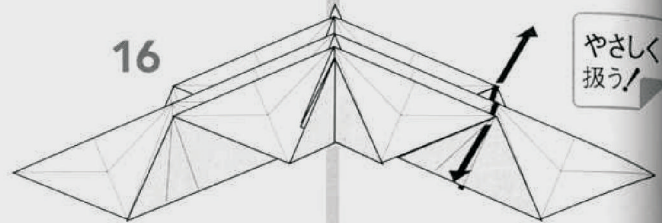

やさしく扱う!

右側も矢印方向に引っ張って極太線を背骨のような山折り線にしなごら、工程14と同じ正方形を伸ばし、カクン折りを2回する

17

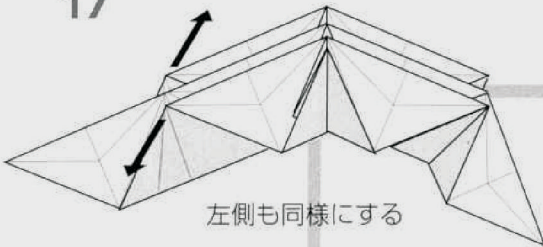

左側も同様にする

工程14~15の「カクン折り」がほどけないようにする。
とても重要!

18

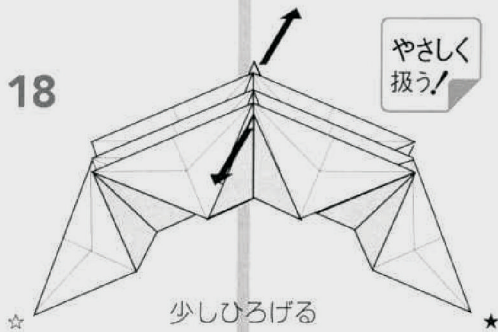

少しひろげる

やさしく扱う!

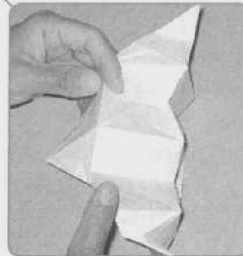

左側の1つ目のカクン折り

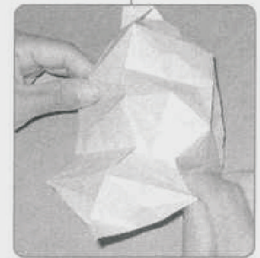

右側の1つ目のカクン折り



19

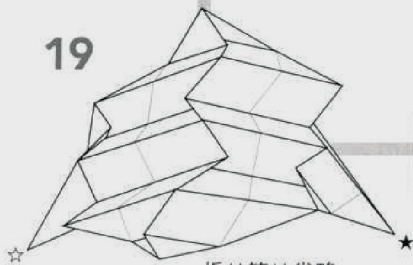

折り筋は省略



20

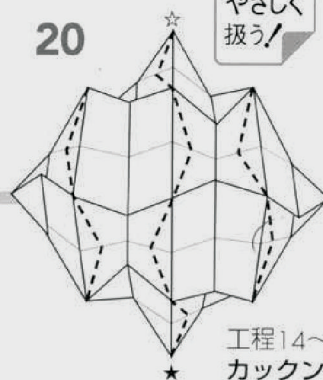

やさしく扱う!

工程14~17同様にカクン折りする

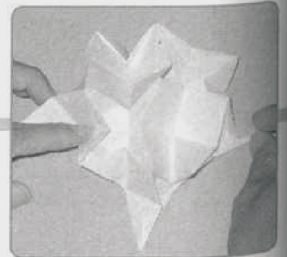

21'

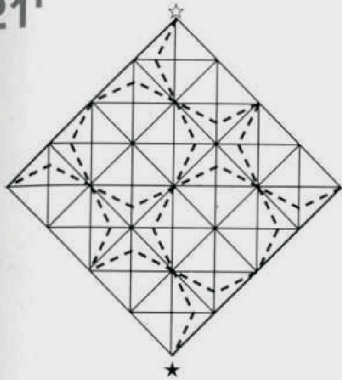

工程21をひろげると、破線でカックン折りしたことがわかる

21

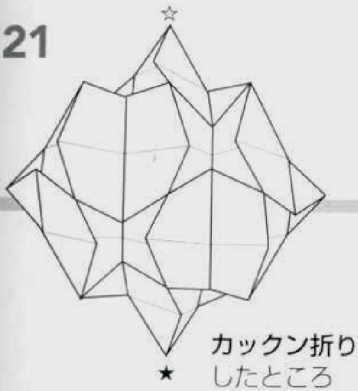

カックン折りしたところ



22

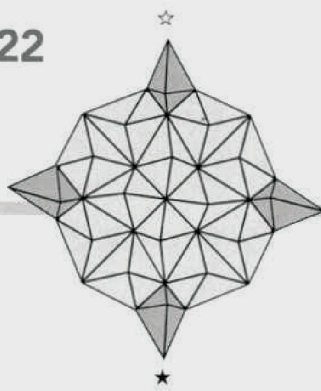

工程22ま上の写真

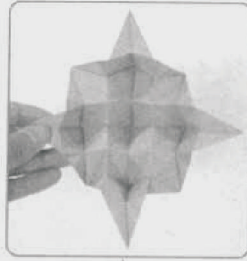

23'

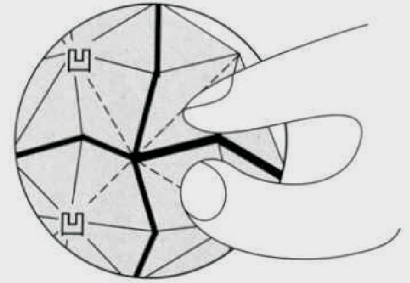

つまんで、極太線をしっかり山折りする



23

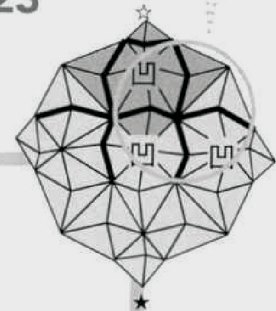

①極太線を強く山折りして、濃い部分をツツジ小パーツと同じものにする
②90°ずつ回転させながら、①を計4回くり返す

「カックン折り」でへこませたところは、この時点ではまだ半開きになっている。

ポイント

24

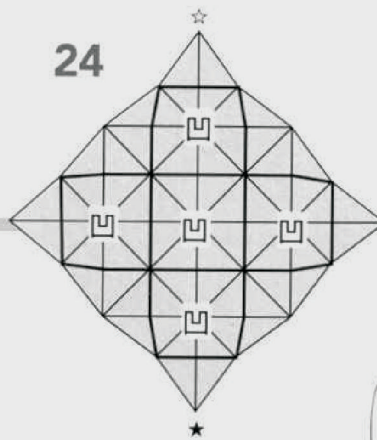

折り目をきれいにするために、以下の工程を行う

次ページへ

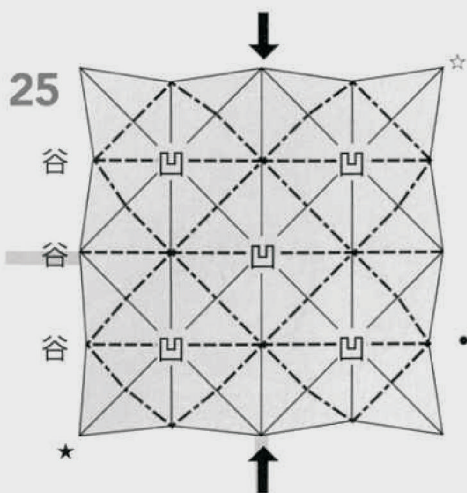

1点鎖線を表から右手でつまみ、破線を裏から左手でつまむと、たたみやすい。
ポイント

1点鎖線を山折り、破線を谷折りしながら、矢印方向に平たくたたむ

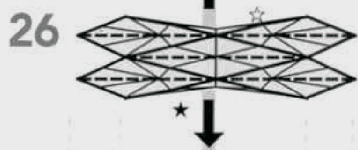

少しひろげる

26''

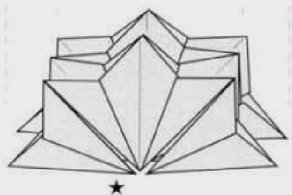

工程26をま横から見たところ



28

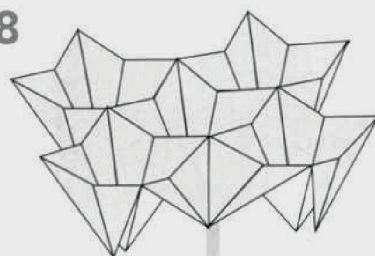

つつじ大パーツ 完成

27'

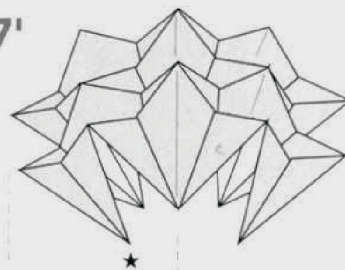

工程27をななめ横から見たところ

27

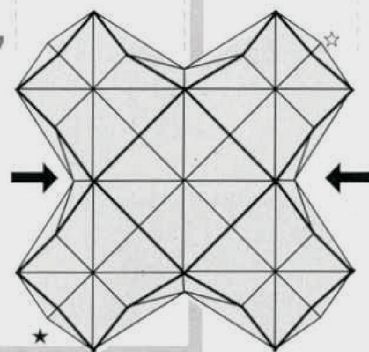

左右からも工程25同様にしっかりとたんでから、工程28になるようひろげる

つつじ組み練習パーツの作り方

つつじを組むための練習パーツを作ります。 (練習用紙) 正方形の紙

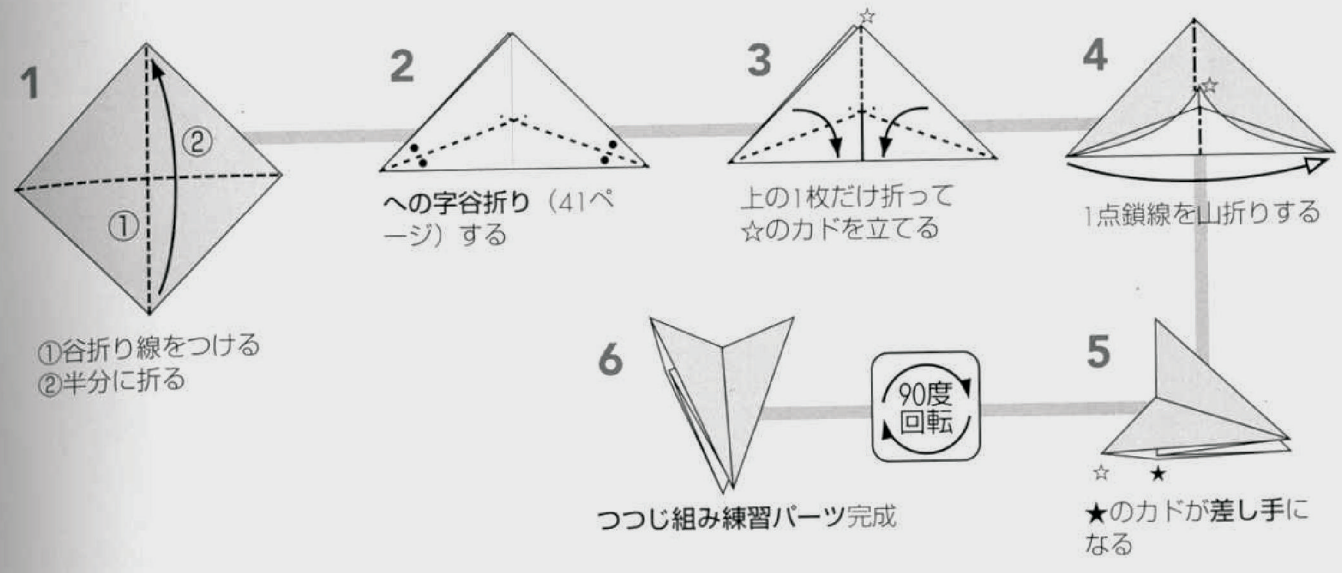

つつじ組みの練習

つつじやしゃくなげは、他のユニット花とは少し違う組み方をします。Step3に移る前に練習しましょう。

(練習用紙) 正方形の紙×2

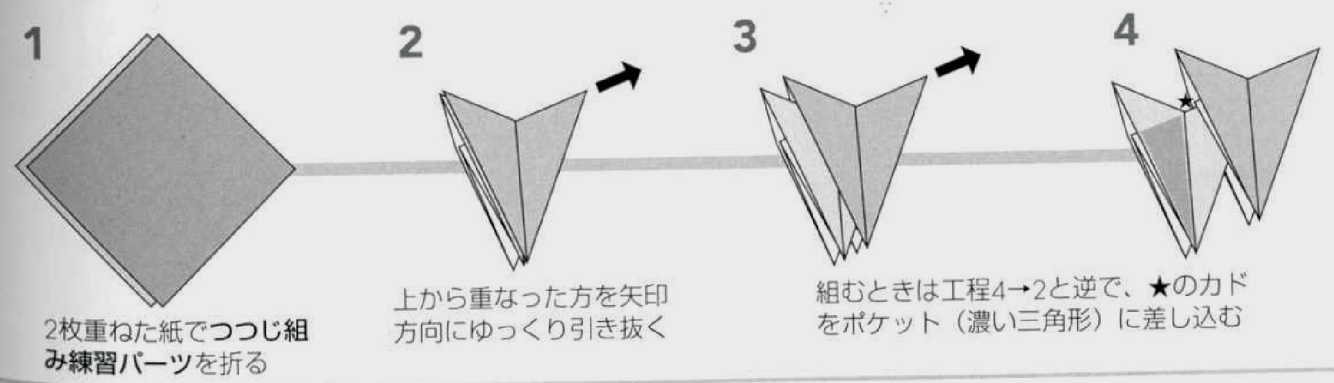
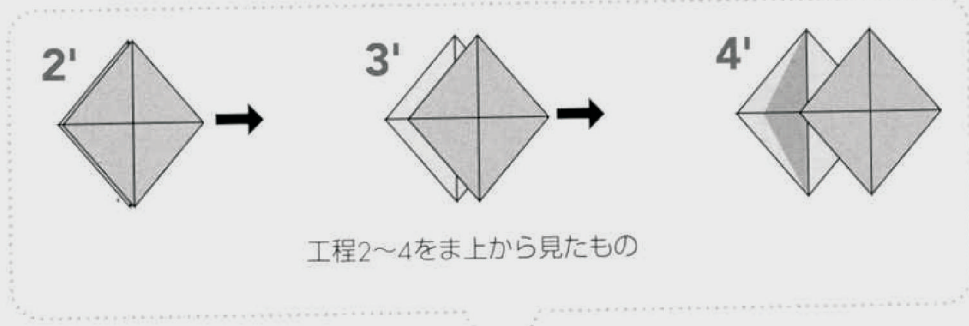

しゃくなげ

難易度
 ★★☆☆☆
 必要な練習
 つつじ

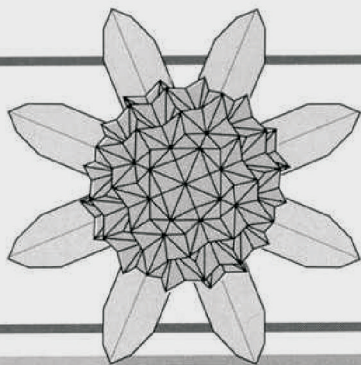

しゃくなげの花は、しゃくなげパーツとつつじ大パーツを組んだものです。しゃくなげパーツは1枚の紙でつつじ大パーツを4つ折ったものです。折り方は同じですので、つつじのStep2 (44ページ)を見ながら折って下さい。

Step▶1

花を作る

練習用紙 30cm×30cm×1、15cm×15cm×1

本番用紙 30cm×30cm×1、15cm×15cm×1

しゃくなげパーツを折る

つつじ大パーツを折る

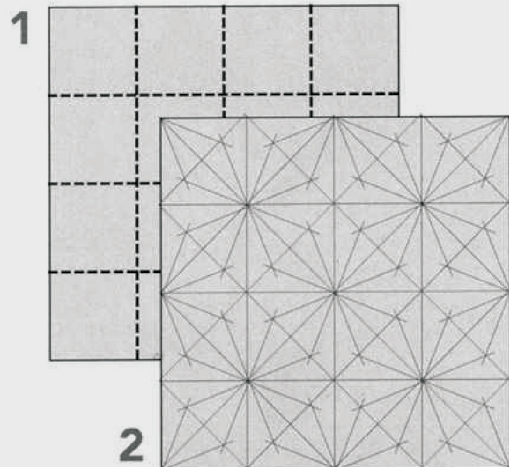
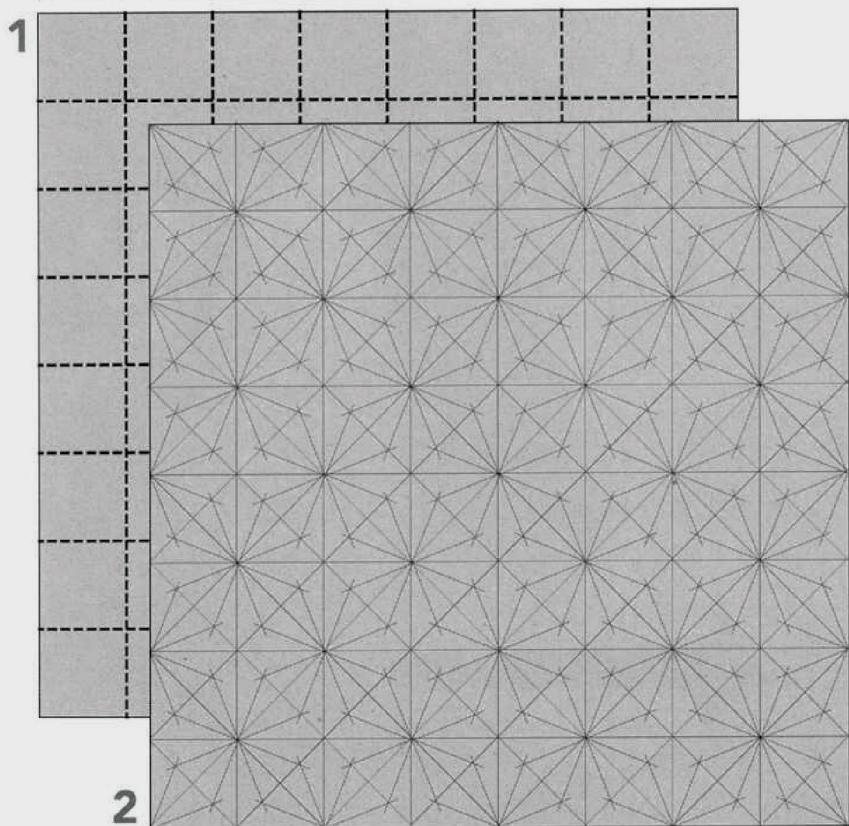

2

2

への字谷折りして、カクン折りする

3

3

4

4

折り方がわからないときは、つつじStep2の「つつじ大パーツを作る」をもう一度おさらいしてください。

ポイント

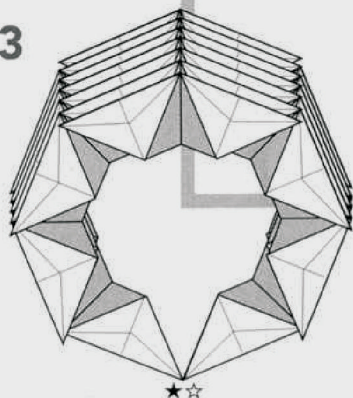

カクン折りがきれいにできていると、★と☆のカドが一致する

★☆

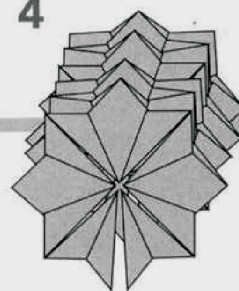

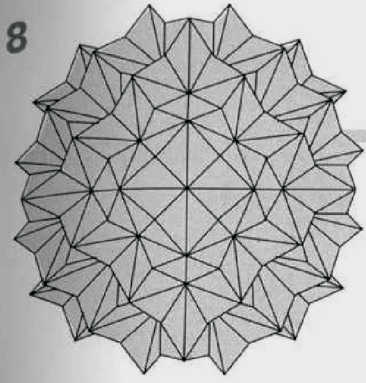

しゃくなげの花完成

MEMO

つつじ組みがとれてしまう場合は、軽く糊づけしてもよい。

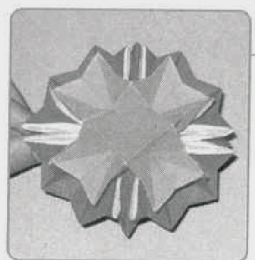

4カ所でつつじ組みしたところ

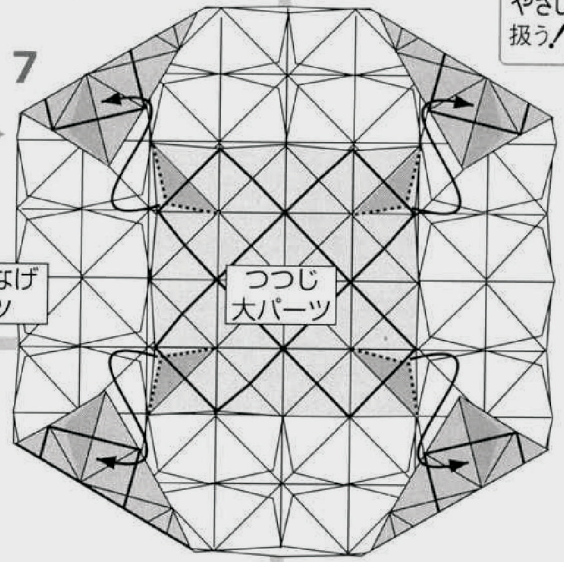

やさしく扱う!

しゃくなげパーツ

つつじ大パーツ

4カ所でつつじ組み (49ページ〜) して、丸く形を整える。ポケットと差し手の役割を逆にしてもよい

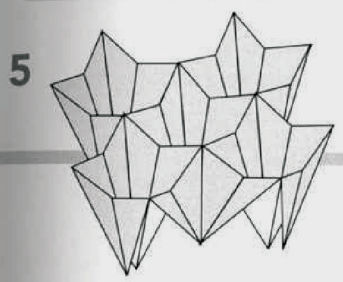

つつじ大パーツ完成

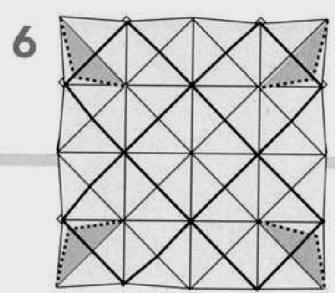

しゃくなげパーツの上へのせる

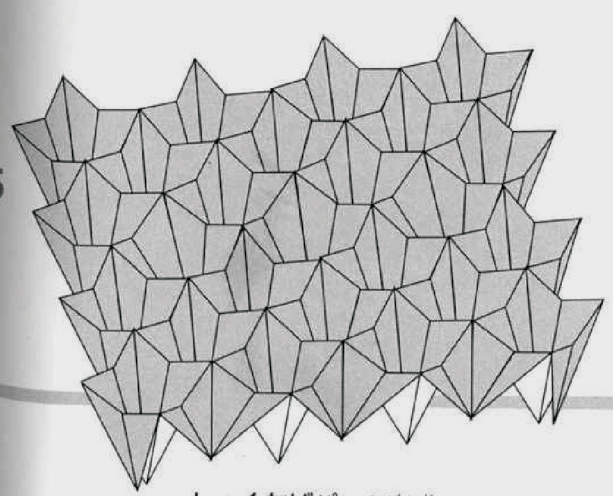

しゃくなげパーツ完成

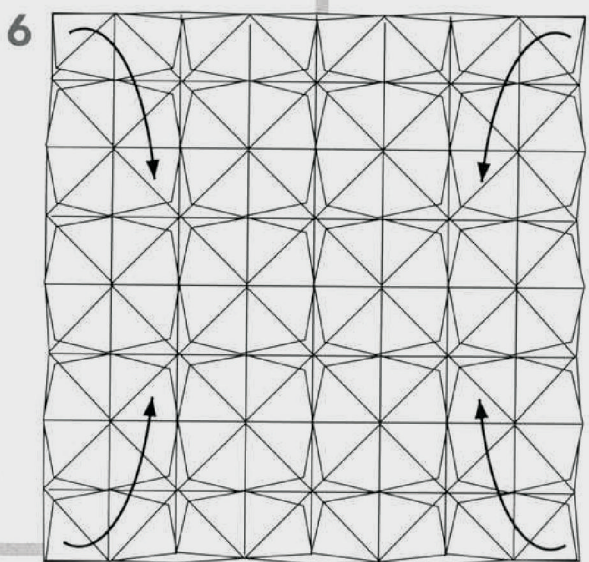

しゃくなげパーツの四隅を曲げて工程7のようにする

Step▶2 葉を作る

練習用紙 15cm×7.5cm×8
本番用紙 12cm×6cm×8

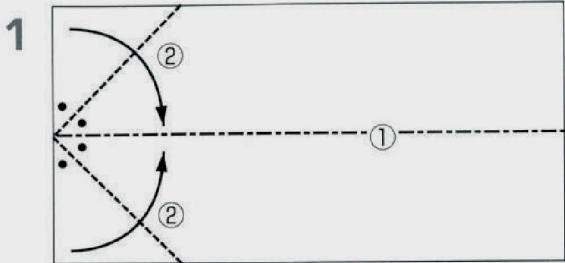

①山折り線をつける ②ななめ45°に折る

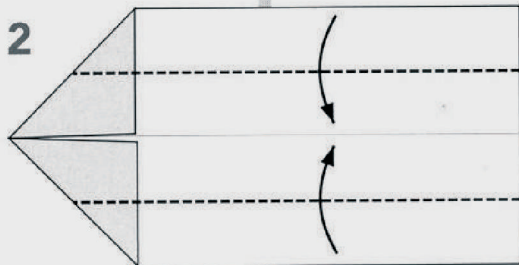

観音折りする

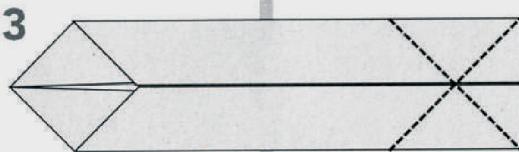

ななめ45°に谷折り線をつける

折り目を
しっかり
つける!

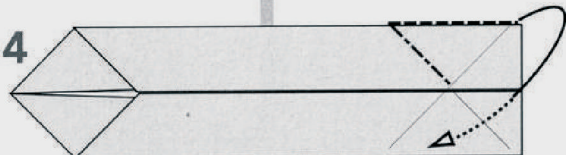

中割り留め (34ページ) する

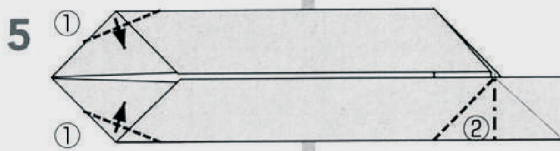

折り目を
しっかり
つける!

①丸みを出すために少し折る
②折り目をつける

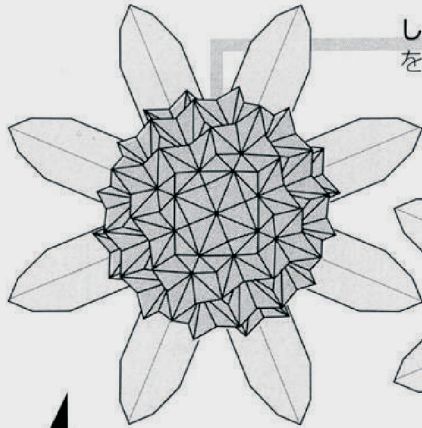
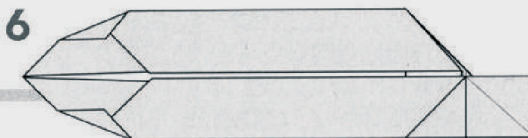

10 しゃくなげ完成

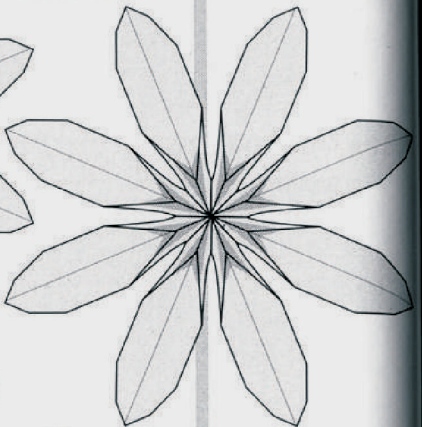

9 しゃくなげの葉完成



葉パーツを8枚組む (35ページ参照)

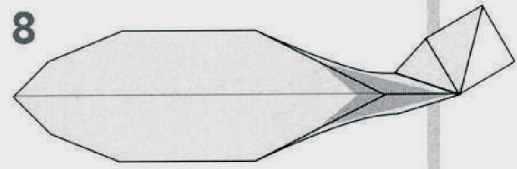

葉パーツ完成

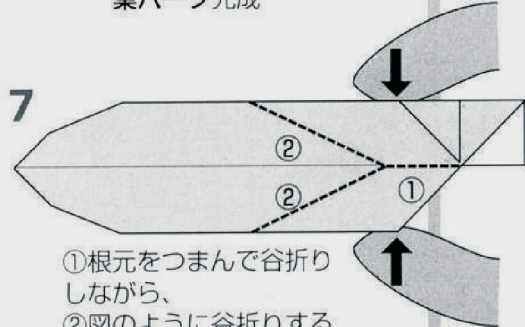

①根元をつまんで谷折りしながら、
②図のように谷折りする

